

TECHNICAL MANUAL

OPERATOR'S MANUAL

**TENT, GENERAL AND SPECIAL USE,
POLE SUPPORTED: ARTIC, 10-MAN
NSN 8340-00-262-2877
ASSEMBLY, M-1942, NSN 8340-00-262-2877;
COMMAND POST, M-1945, NSN 8340-00-269-1370;
HEXAGONAL, LIGHTWEIGHT, M-1950,
NSN 8340-00-269-1372**

**This reprint includes all changes in effect at the time of publication.
See inside front cover for details.**

CHANGE
NO. 3

HEADQUARTERS
DEPARTMENT OF THE ARMY
WASHINGTON, D.C., 4 APRIL 1994

Operator's Manual

TENT, GENERAL AND SPECIAL USE,
POLE SUPPORTED: ARTIC, 10-MAN
NSN 8340-01-059-4075, NSN 8340-00-262-3685;
ASSEMBLY, M-1942, NSN 8340-00-262-2877;
COMMAND POST, M-1945, NSN 8340-00-269-1370;
HEXAGONAL, LIGHTWEIGHT, M-1950, NSN 8340-01-026-6095

DISTRIBUTION STATEMENT A: Approved for public release; distribution is unlimited.

TM 10-8340-222-10, 21 November 1972, is changed as follows:

1. Title is changed as indicated above.
2. Remove and insert pages as indicated below. New or changed text material is indicated by a vertical bar in the margin. An illustration change is indicated by a miniature pointing hand.

Remove pages

i and ii
1-1 and 1-2
B-1 through B-6

Insert pages

i and ii
1-1 and 1-2
B-1 through B-6

3. Retain this sheet in front of manual for reference purposes.

By Order of the Secretary of the Army:

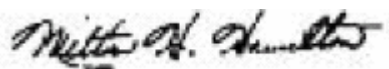

MILTON H. HAMILTON
*Administrative Assistant to the
Secretary of the Army*
0537

GORDON R. SULLIVAN
*General, United States Army
Chief of Staff*

DISTRIBUTION:

To be distributed in accordance with DA Form 12-25-E, block no. 1759, requirements for TM 10-8340-222-10.

CHANGE

NO. 2

HEADQUARTERS
DEPARTMENT OF THE ARMY
WASHINGTON, D.C., 25 MAY 1992

Operator's Manual

**TENT, GENERAL AND SPECIAL USE,
POLE SUPPORTED: ARCTIC, 10-MAN
NSN 8340-00-262-2877
ASSEMBLY, M-1942, NSN 8340-00-262-2877
COMMAND POST, M-1945, NSN 8340-00-269-1370
HEXAGONAL, LIGHTWEIGHT, M-1950, NSN 8340-00-269-1372**

Approved for public release; distribution is unlimited

TM 10-8340-222-10, 21 NOVEMBER 1972, is changed as follows:

1. Remove and insert pages as indicated below. New or changed text material is indicated by a vertical bar in the margin. An illustration change is indicated by a miniature pointing hand.

Remove pages

Insert pages

B-5 AND B-6

B-5 AND B-6

2. Retain this sheet in front of manual for reference purposes.

By Order of the Secretary of the Army:

GORDON R. SULLIVAN
General, United States Army
Chief of Staff

Official:

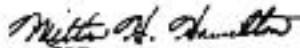

MILTON H. HAMILTON
*Administrative Assistant to the
Secretary of the Army*
01327

DISTRIBUTION:

To be distributed in accordance with DA Form 12-25E, qty rqr block no. 1759.

In this edition of TM 10-8340-222-10, all material from Change 1 has been incorporated into the text of the publication. The next change to this publication will be Change 2 and will print as "remove-and-insert" looseleaf pages. At that time, changed material will be indicated by vertical bars in the margin.

By Order of the Secretary of the Army:

Official:

JOHN A. WICKHAM, JR.
General, United States Army
Chief of Staff

DONALD J. DELANDRO
Brigadier General, United States Army
The Adjutant General

**OPERATOR'S MANUAL
 TENT, GENERAL AND SPECIAL USE,
 POLE SUPPORTED: ARTIC, 10-MAN
 NSN 8340-01-059-4075, NSN 8340-00-262-3685;
 ASSEMBLY, M-1942, NSN 8340-00-262-2877;
 COMMAND POST, M-1945, NSN 8340-00-269-1370;
 HEXAGONAL, LIGHTWEIGHT, M-1950, NSN 8340-01-026-6095**

DISTRIBUTION STATEMENT A: Approved for public release; distribution is unlimited.

REPORTING ERRORS AND RECOMMENDING IMPROVEMENTS

You can help improve this manual. If you find any mistake or if you know of a way to improve the procedures, please let us know. Mail your letter, DA Form 2028 (Recommended Changes to Publications and Blank Forms), or DA Form 2028-2 located in the back of this manual direct to: Commander, U.S. Army Aviation and Troop Command, ATTN: AMSAT-I-MP, 4300 Goodfellow Boulevard, St. Louis, MO 63120-1798. A reply will be furnished directly to you.

CHAPTER 1.	INTRODUCTION		
SECTION I.	General	Paragraph	Page
	Scope	1-1	1-1
	Maintenance forms and records	1-2	1-1
	Reporting of errors	1-3	1-1
	Equipment serviceability criteria (ESC)	1-4	1-1
II.	Description and Data		
	General	1-5	1-1
	Tent, arctic, 10-man	1-6	1-5
	Tent, assembly, M-1942	1-7	1-6
	Tent, command post, M-1945	1-8	1-6
	Tent, hexagonal, lightweight, M-1950	1-9	1-6
	Tabulated data.....	1-10	1-7
CHAPTER 2.	OPERATING INSTRUCTIONS		
SECTION I.	Operating Procedures		
	Site selection	2-1	2-1
	Erecting (pitching) 10-man arctic tent	2-2	2-1
	Striking 10-man arctic tent	2-3	2-5
	Folding 10-man arctic tent	2-4	2-5
	Erecting (pitching) assembly tent M-1942	2-5	2-7
	Striking assembly tent M-1942	2-6	2-11
	Folding assembly tent M-1942	2-7	2-11
	Erecting (pitching) command post tent M-1945	2-8	2-13
	Striking command post tent M-1945	2-9	2-18
	Folding command post tent M-1945	2-10	2-18
	Erecting (pitching) lightweight tent M-1950.....	2-11	2-20
	Striking lightweight tent M-1950	2-12	2-22
	Folding light weight tent M-1950.....	2-13	2-22
II.	Operation Under Unusual Conditions		
	Using the tent in cold climates	2-14	2-24
	Using the tent in wet climates	2-15	2-24

CHAPTER 3.	MAINTENANCE INSTRUCTIONS		
SECTION I.	Lubrication Instructions		
II.	Preventive Maintenance Checks and Services	Paragraph	Page
	General	3-1	3-1
	Preventive maintenance checks and services (table 3-1)	3-2	3-1
SECTION III.	Troubleshooting		
	General	3-3	3-3
	Troubleshooting (table 3-2)	3-4	3-3
IV.	Maintenance Procedures		
	Protection of tent against damage	3-5	3-3
	Protection of pins, poles, and lines against damage	3-6	3-4
APPENDIX A.	REFERENCES		A-1

LIST OF ILLUSTRATIONS

<i>Figure</i>	<i>Caption</i>	<i>Page</i>
1-1	Tent, arctic, 10-man	1-2
1-2	Tent, assembly, M-1942	1-3
1-3	Tent, command post, M-19-4	1-4
1-4	Tent, hexagonal, lightweight, M-1950	1-5
2-1	Ground plan, arctic 10-man tent	2-2
2-2	Steps in pitching tent, arctic 10-man	2-3
2-3	Joining two tents together by chain-lacing beackets through grommets	2-5
2-4	Steps in folding tent, arctic, 10-man	2-6
2-5	Ground plan, assembly tent M-1942	2-7
2-6	Steps in pitching tent, assembly, M-1942 (sheet 1 of 2)	2-8
2-6	Steps in pitching tent, assembly, M-1942 (sheet 2 of 2)	2-9
2-7	Preparing center pole for erection of tent, assembly, M-1942	2-9
2-8	Steps in lacing top sections together (tent, assembly, M-1942)	2-10
2-9	Lacing sections to bail rings (tent, assembly, M-1942)	2-11
2-10	Steps in folding tent, assembly, M-1942	2-12
2-11	Ground plan of tent, command post, M-1945	2-13
2-12	Steps in pitching tent, command post, M-1945	2-15
2-13	Steps in attaching liner to tent, command post, M-1945	2-17
2-14	Attaching screens to sidewalls of tent, command post, M-1945	2-18
2-15	Steps in folding tent, command post, M-1945	2-19
2-16	Ground plan of tent, hexagonal, lightweight, M-1950	2-20
2-17	Steps in pitching tent, hexagonal, M-1950	2-21
2-18	Steps in folding tent, hexagonal, M-1950	2-23

CHAPTER 1

INTRODUCTION

Section I. GENERAL

1-1. Scope

This manual is for your use in erecting, striking and maintaining the 10-man arctic tent, assembly tent M1942, command post tent M1945, and the lightweight hexagonal tent M1950.

1-2. Forms and Records

Maintenance forms and records that you are required to use are explained in TM 38-750.

1-3. Reporting Errors and Recommending Improvements

You can help improve this manual. If you find any mistake or if you know of a way to improve the procedures, please

let us know. Mail your letter, DA Form 2028 (Recommended Changes to Publications and Blank Forms), or DA Form 2028-2 located in the back of this manual direct to: Commander, US Army Aviation and Troop Command, ATTN: AMSAT-I-MP, 4300 Goodfellow Boulevard, St. Louis, MO 63120-1798. A reply will be furnished directly to you.

1-4. Equipment Serviceability Criteria (ESC).

This equipment is not covered by an ESC.

Section II. DESCRIPTION AND TABULATED DATA

1-5. General

Refer to figures 1-1 through 1-4 for an illustrated description of the 10-man arctic tent, assembly tent M1942, command post tent M1945, and the lightweight

tent M1950. The following paragraphs provide a general description for each tent.

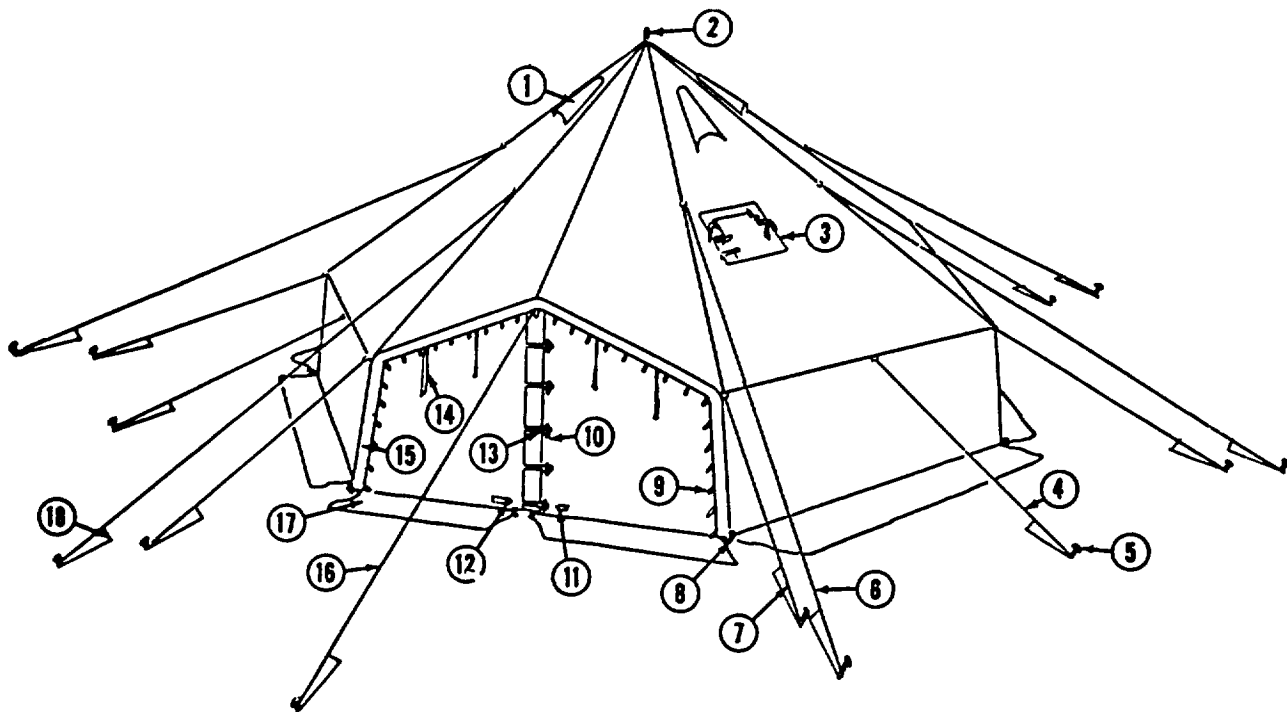

- | | | |
|-----------------------|--------------------------|-------------------------|
| 1 Ventilator | 7 Tent line, corner eave | 13 Toggle loop |
| 2 Telescopic tentpole | 8 Footstop | 14 Tie tape |
| 3 Stovepipe opening | 9 Becket | 15 Tent lug |
| 4 Tent line, eave | 10 Wood toggle | 16 Tent line, door eave |
| 5 Aluminum tent pin | 11 Chape snap | 17 Snow cloth |
| 6 Tent line, corner | 12 D-ring | 18 Tent slip |

ME 8340-22-10/1-1

Figure 1-1. Tent, arctic, 10-man.

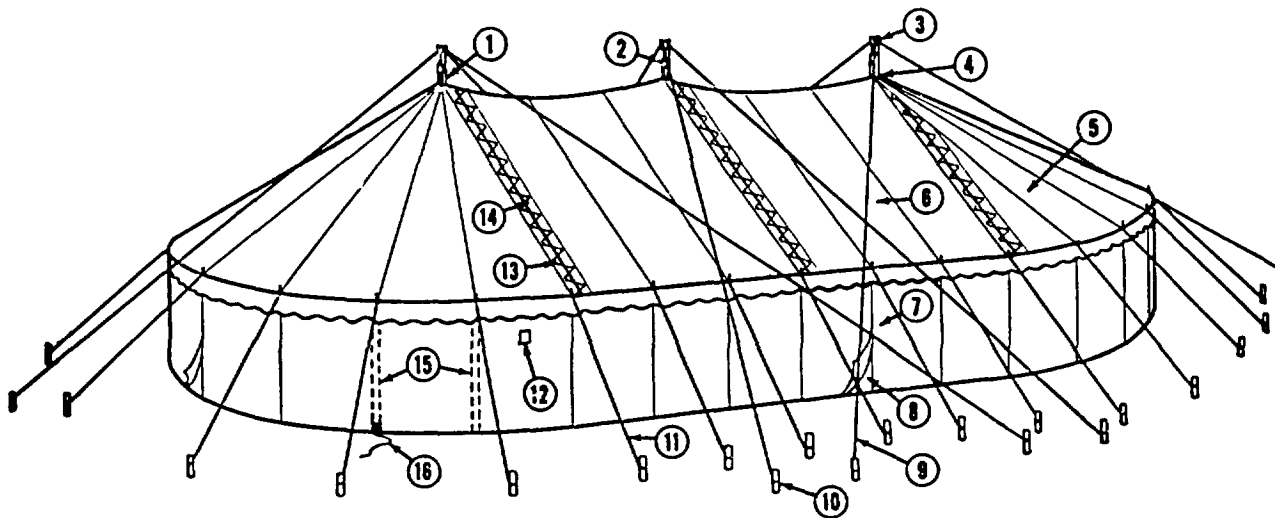

- | | | |
|--------------------------------|--------------------------|--------------------------------|
| 1 Center pole | 7 Wall section | 13 Extension cloth lacing line |
| 2 Block and tackle | 8 Door opening | 14 Extension cloth |
| 3 Ferrule (cap at top of pole) | 9 Long guy line | 15 Eave pole |
| 4 Tent chain and ring | 10 36-inch wood tent pin | 16 Long wall tie line |
| 5 End section | 11 Eave line | |
| 6 Middle section | 12 Stovepipe opening | |

ME 8340-222-10/1-2

Figure 1-2. Tent, assembly, M-1942.

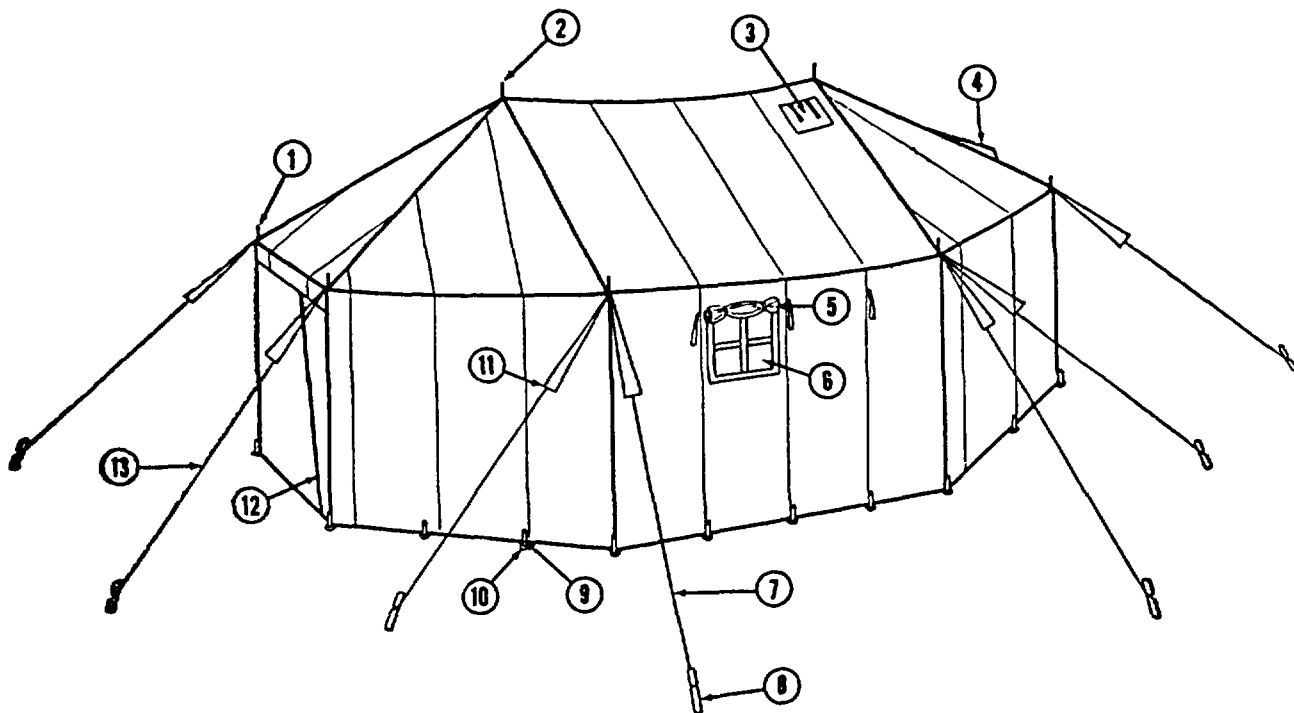

- | | | |
|---------------------|-------------------------|---------------------------|
| 1 Eave pole | 6 Window, w/o screening | 11 Tent slip |
| 2 Center pole | 7 Corner line | 12 Vestibule door opening |
| 3 Stovepipe opening | 8 24-inch wood tent pin | 13 Door eave line |
| 4 Ventilator | 9 16-inch wood tent pin | |
| 5 Window flap | 10 Footstop | |

ME 8340-222-10/1-3

Figure 1-3. Tent, command post, M-1945.

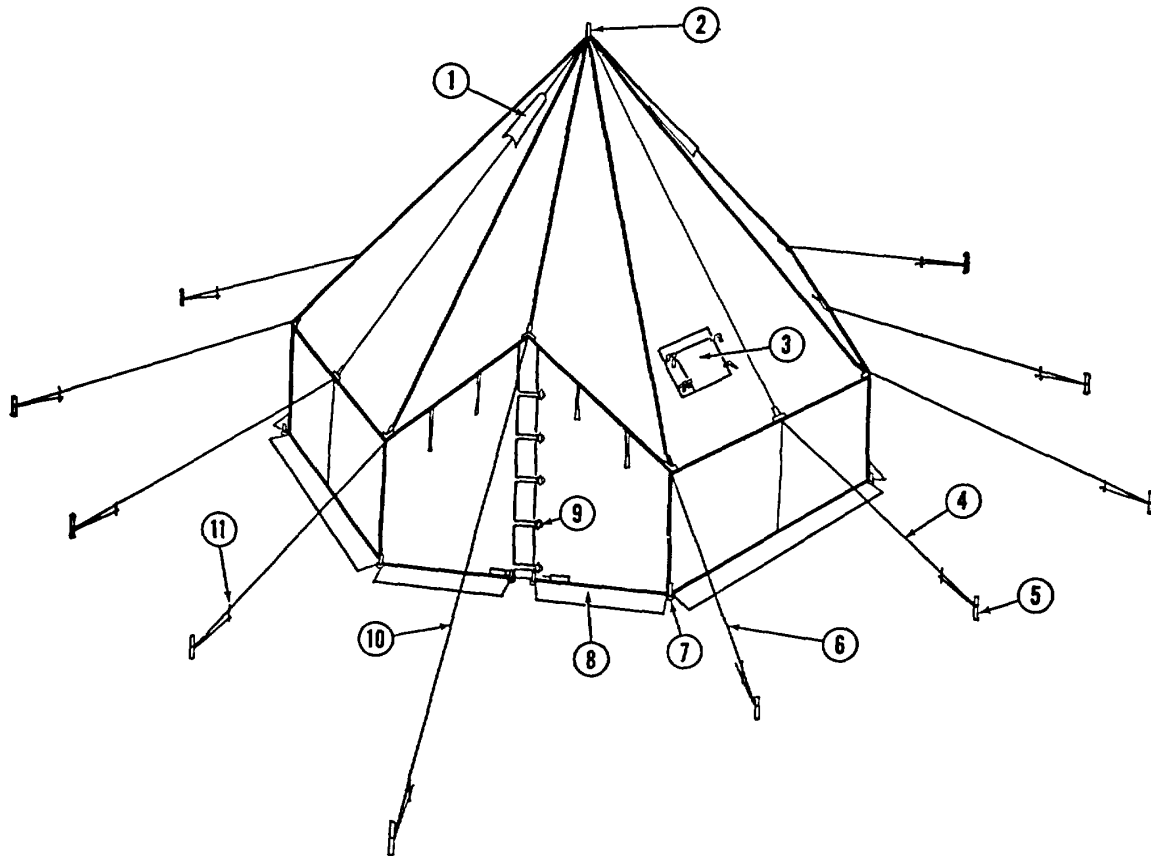

- | | | |
|--------------------------|----------------------------|--------------------|
| 1 Ventilator | 5 9-inch aluminum tent pin | 9 Wood tent toggle |
| 2 Telescopic tentpole | 6 Corner eave line | 10 Door eave line |
| 3 Stovepipe opening | 7 Footstop | 11 Tent slip |
| 4 Intermediate eave line | 8 Snow cloth | |

ME 8340-222-10/1-4

Figure 1-4. Tent, hexagonal, lightweight, M-1950

1-6. Tent, Arctic, 10-Man

a. Description and Use. The 10-man arctic tent (fig. 1-1) is a six-sided pyramidal tent supported by a telescopic center pole. It is used to provide shelter for 10-men with equipment under arctic conditions. It also may be used as a command post tent or as a small storage tent.

b. Material. The tent is made of 8.5-ounce olive-drab wind-resistant sateen cotton cloth which is coated with a weather, water, and mildew-resistant compound.

c. Doors. The tent has two doors 5 feet high on opposite sides, permitting tents to be joined together with suitable access from one to the other. Door

flaps may be securely closed either by slide fasteners or by loops over wood toggles. The doors are operated from both inside and outside.

d. Ventilation. The tent has four built-in ventilators on opposite sides and near the peak of the tent. The ventilators have inside ducts, which may be closed by tie cords. The ventilator hoods are of the fixed type, each hood being constructed with a stiffener in the hem to keep it extended out from the ventilator opening.

e. Heating. The tent is heated by an M-1950 Yukon stove. A stovepipe opening with a silicone rubber-molded ring is built in one side of the tent near the eave. When the stove is not in use, the

stovepipe opening can be protected by a canvas flap.

f. Snow Cloths. There is a snow cloth sewed to the bottom of each side of the tent. When the tent is pitched, the snow cloths are flat on the ground on the outside of the tent. Snow is deposited on the snow cloths for insulation purposes.

g. Screen Doors. Screen doors are attached to the front and rear of the tent for protection against insects.

h. Sock Lines. Four sock lines are provided for drying clothing and equipment.

i. Liner. A fire-resistant liner, made of 5.2-ounce permeable cotton sheeting, is provided to insulate the tent and to prevent front from falling on the occupants. The liner is held in place by metal toggles.

j. Cover. The tent is provided with a cover for use when it is in storage or is being transported. The tent and liner, when folded fit into the cover. Aluminum tent pins are nested and the magnesium pole telescoped to its shortest length and placed in the packet at one side of the cover.

1-7. Tent, Assembly, M-1942

a. Description and Use. The assembly tent (fig. 1-2) is a large general purpose tent, with a rectangular middle section and rounded hip-roofed ends. The top is made in four sections which lace together; two middle sections and two rounded end sections. The sidewall is in four sections. There are three chains and supporting rings and three sets of block and tackle with lines. Since the tent is sectional in construction, it may be extended to any desired length by means of additional middle and wall sections. Two end sections can be joined and used with two wall sections to form a circular tent. The assembly tent is used for church services, lectures, and for showing movies. It may also be used for storage, for quartering personnel, or for any other authorized purpose. When used for quartering personnel, it has a capacity of approximately 80 men.

b. Material. The middle and end sections are made of 12.29-ounce duck which is coated with a fire, water, weather, and mildew-resistant compound. The wall sections are made of 9.85-ounce duck.

c. Door Openings. The tent has four door openings, each of which is made by the overlapping of a panel and a half of sidewall where two sections of the sidewall meet. The sidewalls may be shifted so that the openings come anywhere as long as the same proportionate distance between the openings is maintained.

d. Ventilation. There are four built-in ventilators, one to each side-wall section. The tent can also be ventilated by rolling up the sidewalls and tying them with the attached tie tapes; or if it is raining, by extending the sidewall and tying it to the lines running from the eaves. The doors can also be tied back and the opening used for ventilation.

e. Heating. Four M-1941 tent stoves or two external 250,000-B.T.U. tent heaters, are used to heat the tent. The built-in ventilators are used as stovepipe openings when M-1941 tent stoves are used.

f. Covers. The tent is provided with six covers for use when in storage or when being transported.

1-8. Tent, Command Post, M-1945

a. Description and Use. The central part of the command post tent (fig. 1-3) is A-shaped. The ends are hip-roofed with converging sidewalls. The tent is used to provide space for staff sections, accommodating three men and the necessary folding tables and office equipment. It may also be used for quartering of three officers or as a battalion aid station, the blackout vestibule being long enough to accommodate a litter and bearers.

b. Material. The tent is made of 12.29-ounce duck which is coated with a fire, water, weather, and mildew-resistant compound. The canvas is supported on a webbing framework which carries the weight of the canvas. Fair-leads carry the stress between webbing and eave lines and eliminate friction between eave and eave lines. The tent walls, tent top, and sod cloth are constructed of one piece.

1-9. Tent, Lightweight, M-1950

a. Description and Use. The M-1950 lightweight tent (fig. 1-4) is a six-sided pyramidal tent, supported by a telescopic center pole. It is used to provide shelter for personnel operating in extremely cold-dry or cold-wet areas. Normally, the tent will accommodate five men and their individual clothing and equipment; under emergency conditions, the tent will provide shelter for five men sleeping and one on watch.

b. Material. The tent is made of plied yarn, wind-resistant, sateen cotton cloth which is coated with fire, water, weather and mildew-resistant compound; it weighs approximately 9 ounces per square yard.

c. Door. The tent has one door 5 feet high, which is located in the center of one side. Door flaps may be closed either by the slide fastener or by loops over wood toggles.

d. *Ventilation.* The tent is ventilated by two built-in ventilators on opposite sides and near the peak of the tent. The ventilators have inside ducts, which can be closed by tie cords. The ventilator hoods are of the fixed type, each hood being made with a stiffener inserted in the hem to keep it extended out from the ventilator opening.

e. *Heating.* The tent is heated by an M-1950 Yukon stove. A stovepipe opening with a silicone rubber-molded ring is built in one side of the tent near the eave. When the stove is not in use, the stovepipe opening can be protected by a canvas flap.

f. *Sock Lines.* Three sock lines are provided for drying clothing and equipment.

g. *Snow Cloths.* There is a snow cloth sewed to the bottom of each side of the tent. When the tent is pitched, the snow cloths are flat on the ground on the outside of the tent. Snow is deposited on the snow cloths for insulation purposes.

h. *Liner.* A fire-resistant liner, made of 5.2 ounce cotton cloth, is provided to insulate the tent and to prevent frost from falling on the occupants. The liner is held in place by metal toggles.

i. *Cover.* The tent is provided with a cover for use when it is in storage or is being transported. The tent and liner, when folded, fit into the cover. Aluminum tent pins are nested, and the magnesium pole is telescoped to its shortest length and placed in the packet at one side of the cover.

1-10. Tabulated Data

a. *10-Man Arctic Tent.*

- (1) Height: Peak 8 feet 6 inches; eave 3 feet
- (2) Length: Each side 8 feet 9 inches long

(3) Width: Hexagonal floor diameter 17 feet 6 inches

(4) Weight: Tent and liner 68 pounds; pins and pole 8 pounds

(5) Cube: Tent and liner 7.1 cubic ft; pins and pole 0.2 cubic ft

(6) Floorspace: 198.9 square feet

b. *M-1942 Assembly Tent.*

(1) Height: Peak 18 feet; eave 8 feet

(2) Length: 80 feet

(3) Width: 40 feet

(4) Weight: Tent 1,100 pounds; pins and poles 655 pounds

(5) Cube: 100 cubic feet

(6) Floorspace: 2,856.6 square feet

c. *M-1945 Command Post Tent.*

(1) Height: Peak 9 feet; sidewall 5 feet 6 inches

(2) Length: 20 feet 7 inches

(3) Width: 10 feet

(4) Weight: Tent 165 pounds; pins and poles 92 pounds

(5) Cube: Tent 6.3 cubic feet; pins and poles 3.6 cubic feet

(6) Floorspace: 172 square feet, of which 48 square feet is vestibule space

d. *M-1950 Lightweight Hexagonal Tent.*

(1) Height: Peak 8 feet 6 inches; eave 2 feet

(2) Length: Each side 6 feet 7 inches

(3) Width: Diameter of hexagonal floor 13 feet 3 inches

(4) Weight: Tent and liner 48 pounds; pins and pole 8 pounds

(5) Cube: 3.8 cubic feet

(6) Floorspace: 113.2 square feet

CHAPTER 2 OPERATING INSTRUCTIONS

Section I. OPERATING PROCEDURES

2-1. Site Selection

Consider the following points when selecting a tent site:

a. The ground should be level and free from projecting roots and rocks. When such a spot is not available, a place can often be leveled and cleared. In woods, moss and rocks can be used to level the ground.

b. The ground should be high enough for good drainage.

NOTE

Drainage can be improved by trenching around the tent and digging an outlet ditch to divert water in the desired direction. Refer to paragraph 2-15 for trenching details.

c. The site should be protected from wind and storm.

d. An area with a ground cover of tough turf grass is desirable.

e. During hot weather, when possible, select a site that will provide ample shade.

f. The tent should be placed far enough from

rivers and lakes so that it will be above the highwater mark.

g. In woods, the location should be away from dead trees with large dead branches.

h. In mountainous country, the tent should not be placed in a canyon or next to a dry creek bed. Such places can fill up with rushing torrents in a short time. The tent should not be placed at the base of a cliff or steep mountainside, where there may be danger from avalanches and falling rocks.

i. Discretion should be exercised when installing tent pins in winter climatic conditions where the temperature falls below freezing. In areas where winter conditions prevail the use of the 12 inch steel tent pins (NSN 8340-00-823-7451) is required rather than the 9 inch aluminum pins furnished with erection kits. Attempts to install the aluminum pins under winter conditions will only result in bending and breaking the pins.

2-2. Erecting (Pitching) Arctic Tent (10-Men)

NOTE

The arctic tent can be pitched by six men in approximately 27 minutes.

a. *Ground Plan.* Before pitching the tent, study the ground plan carefully (fig. 2-1).

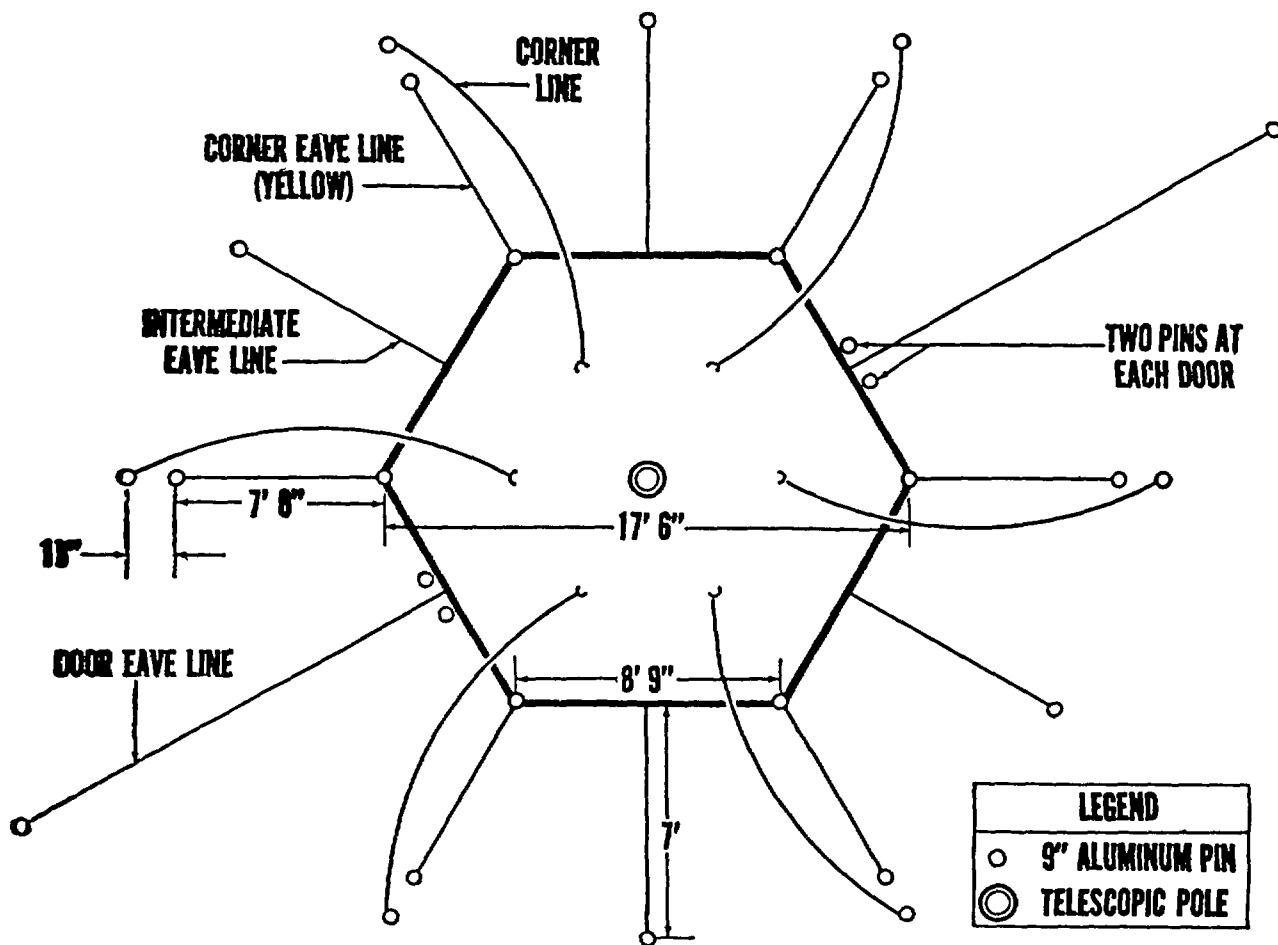

ME 8340-222-10/2-1

Figure 2-1. Ground plan, arctic 10-man tent.

b. Preliminary Procedures (1, fig. 2-2).

(1) Spread tent on ground. Check to see if liner is in place; usually it is not in place in a new tent. If liner is not in place, spread it out beneath the tent.

(2) Secure D-rings to snaps inside front and rear doors.

(3) Close slide fasteners in front and rear doors.

(4) Secure D-rings to snaps outside front and rear doors.

(5) Drive six corner pins and four door pins, and attach footstops to pins.

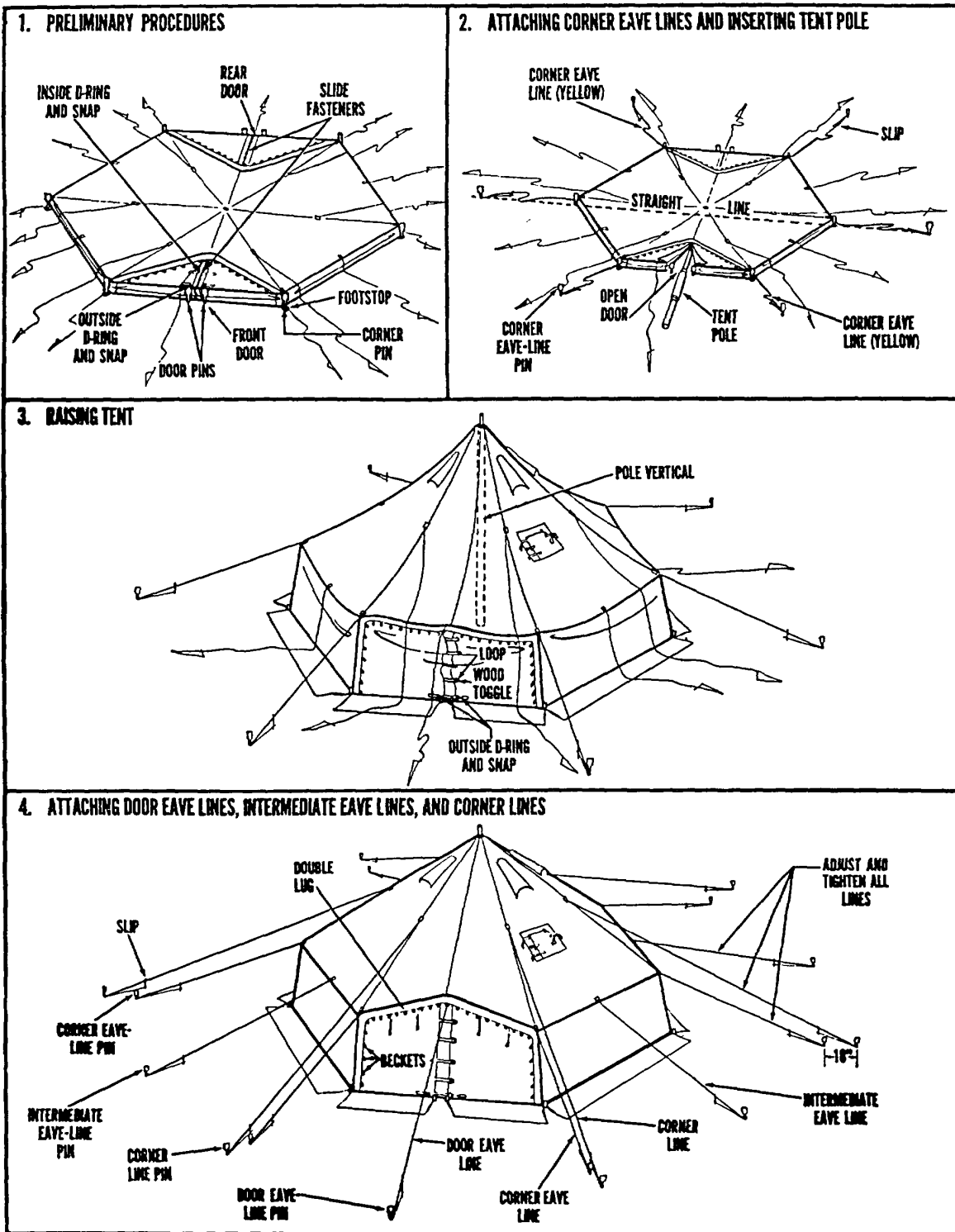

ME 8340-222-10/2-2

Figure 2-2. Steps in pitching tent, arctic, 10-man.

c. Attaching Corner Eave Lines and Inserting Tentpole (2, fig. 2-2).

(1) Drive six pins about seven feet from corners of tent, and attach corner eave lines. Pins on opposite sides of tent should be in a straight line.

(2) Open front door and push pole, extended to 8 feet 6 inches, under tent.

(3) Insert spindle of pole through hole in peak of liner and through supporting ring in peak of the tent.

d. Raising Tent (3, fig. 2-2).

(1) With one man inside the tent, close inside and outside D-rings and snaps on doors; close slide fasteners.

(2) Fasten loops to wood toggles on doors.

(3) Lift tentpole, and line up door openings, stovepipe, and four vent openings of liner with openings in tent.

(4) Insert D-rings of liner into snaps attached to tent.

(5) Raise tentpole, placing butt of tentpole in center of tent area.

e. Attaching Door Eave Lines, Intermediate Eave Lines and Corner Lines (4, fig. 2-2).

(1) Stake the two door eave lines far enough to hold doors vertical.

(2) Attach the four intermediate eave lines to pins.

(3) Attach the six corner lines to pins 18 inches out from corner eave-line pins.

(4) Adjust and tighten all lines.

f. Propping Up Door Eave Lines. Each of the two door eave lines can be propped up by placing the line over an improvised pole (tree branch or other

object higher than the door entrance) at a distance of about 5 feet in front of the door and then staking the line out to a pin. This keeps the doors from sagging, makes the slide fasteners work better, makes the tent easier to get into and out of, and gives the tent greater stability.

g. Fastening Liner.

(1) Insert metal toggles through grommets of liner.

(2) Tie tapes around stovepipe opening in liner to corresponding tapes around stovepipe opening in tent to keep stovepipe opening in place.

(3) Tie one end of the 18-foot 9-inch sock line to toggle in each corner of door, threading line through eye of toggles at eave line and tying to carrier toggles of the opposite door. Use same procedure for the 18-foot 9-inch sock line on opposite side of tent.

(4) Thread the 40-foot 6-inch sock line through the next line of toggles, encircling the tent, and tie.

(5) Secure the 38-foot 6-inch sock line in like manner in the next row of toggles.

h. Joining Two Tents Together. When two tents are to be joined together, erect the first tent described above. Fasten lugs (4, fig. 2-2) at front or rear of tents together by inserting grommet lug of one tent between grommet lug and becket lug of other tent, and chain-lace becket lugs (4, fig. 2-2) on lug of one tent through grommets on each lug of both tents (fig. 2-3). Begin chain-lacing at bottom (near the ground) of lugs and continue until bottom (near the ground) at the other end of the same lugs is reached, securing last becket with a knot. Then erect second tent in the same manner as first tent.

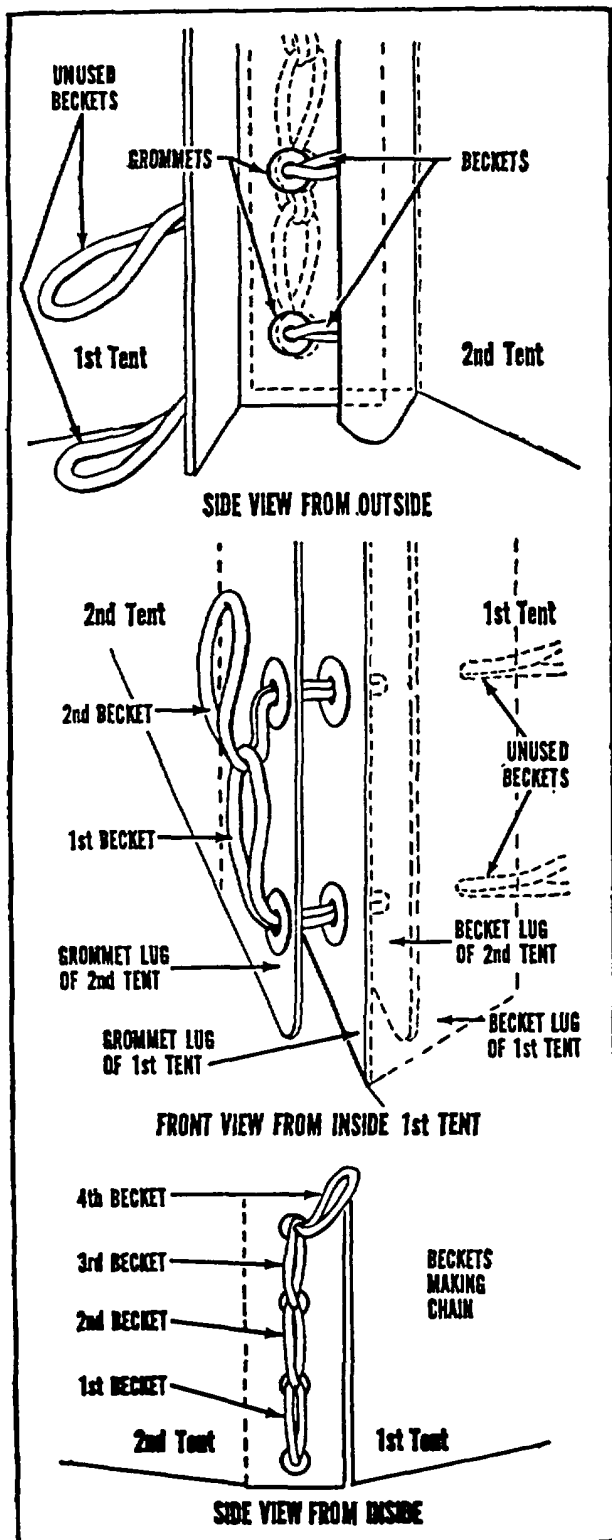

ME 8340-222-10/2-3

Figure 2-3. Joining two tents together by chain-lacing becketts through grommets

2-3. Striking, Arctic Tent

- a. Remove door eave lines from pins.
- b. Loosen footstops from pins and remove foot-stop pins.
- c. Loosen all other lines and remove all other pins.
- d. Remove tentpole, and telescope pole to its shortest length.
- e. Remove liner only if repairs are needed.

2-4. Folding, Arctic Tent

- a. *Folding Tent (fig. 2-4).*
 - (1) Engage snap into D-ring inside doors, and close door slide fasteners.
 - (2) Spread tent on ground and locate stovepipe opening panel. Grasp corner eave line (to right of stovepipe opening) and pull out corner of panel. Then coil intermediate eave line neatly on extended panel (1).
 - (3) Reaching to the left, grasp corner eave line (to left of stovepipe opening) and pull second panel to the right, making an accordion fold (2).
 - (4) Fold remaining panels in the same manner, having six folds in all. As each fold is completed, coil intermediate eave lines or door eave lines neatly between folds (3).
 - (5) Coil on top of folded tent panels the six corner lines, the six corner eave lines that have been drawn to the right, and the last remaining intermediate eave line (4).
 - (6) Grasp peak of tent and fold so that peak extends down tent deck approximately 4 feet. Fold snow cloth up over sidewalls of tent (5).
 - (7) Fold tent approximately in half along its long dimension (6).
 - (8) Fold edges of tent toward center so that no portion of liner is exposed. Place folded tent on cover, place folded screen doors on top of folded tent, and place nested pins and telescoped pole into pocket of cover (7).
 - (9) Close cover securing it with straps and loops. Care should be taken that no portion of the tent is exposed and that the flaps are tucked neatly within the cover.

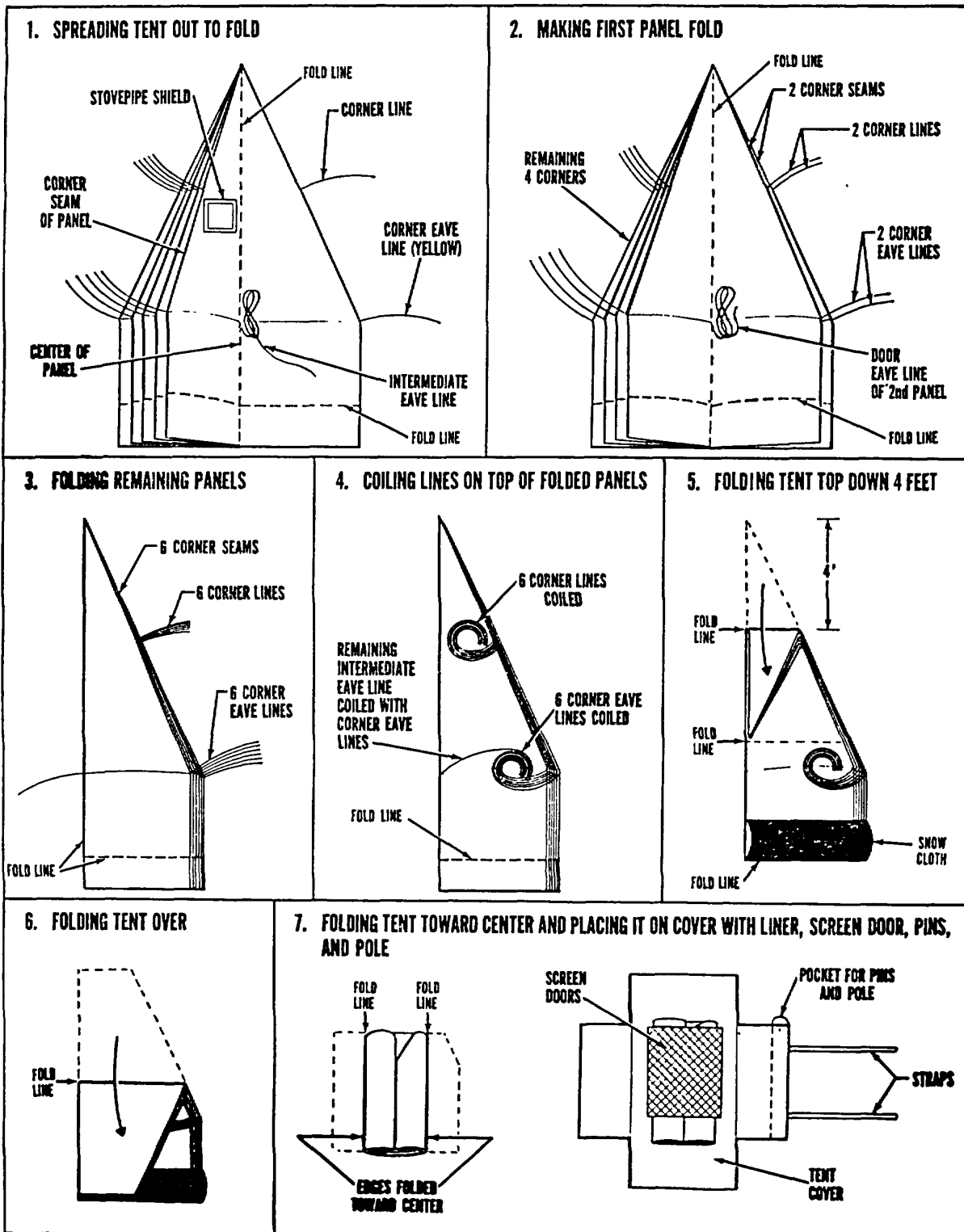

ME 8340-222-10/2-4

Figure 2-4. Steps in folding tent, arctic, 10-man.

b. *Folding Liner.* Ordinarily, the liner is not removed from the tent. When necessary, the liner may be folded separately in the same manner as the tent and placed inside the cover with the tent, screen doors, pins, and pole.

NOTE
The assembly tent can be pitched by nine men in approximately 90 minutes.

2-5. Erecting (Pitching) Assembly Tent (M-1942)

a. *Ground Plan.* Before pitching the tent, study the ground plan carefully (fig. 2-5).

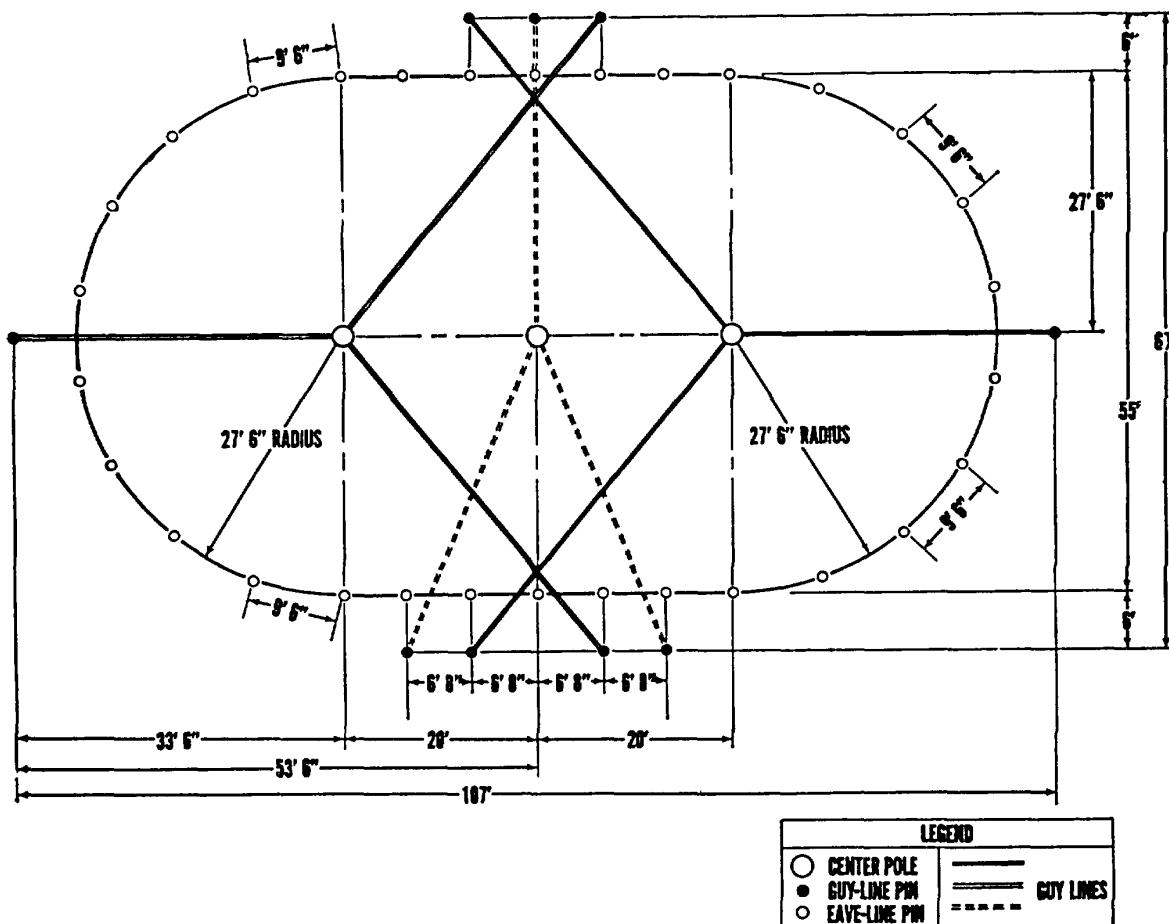

ME 8340-222-10/2-5

Figure 2-5. Ground plan, assembly tent M-1942.

b. *Spotting Center Poles (1, fig. 2-6).* Spot the three center poles according to ground plan and

place a marker at each location. Drive marker in about 6 inches.

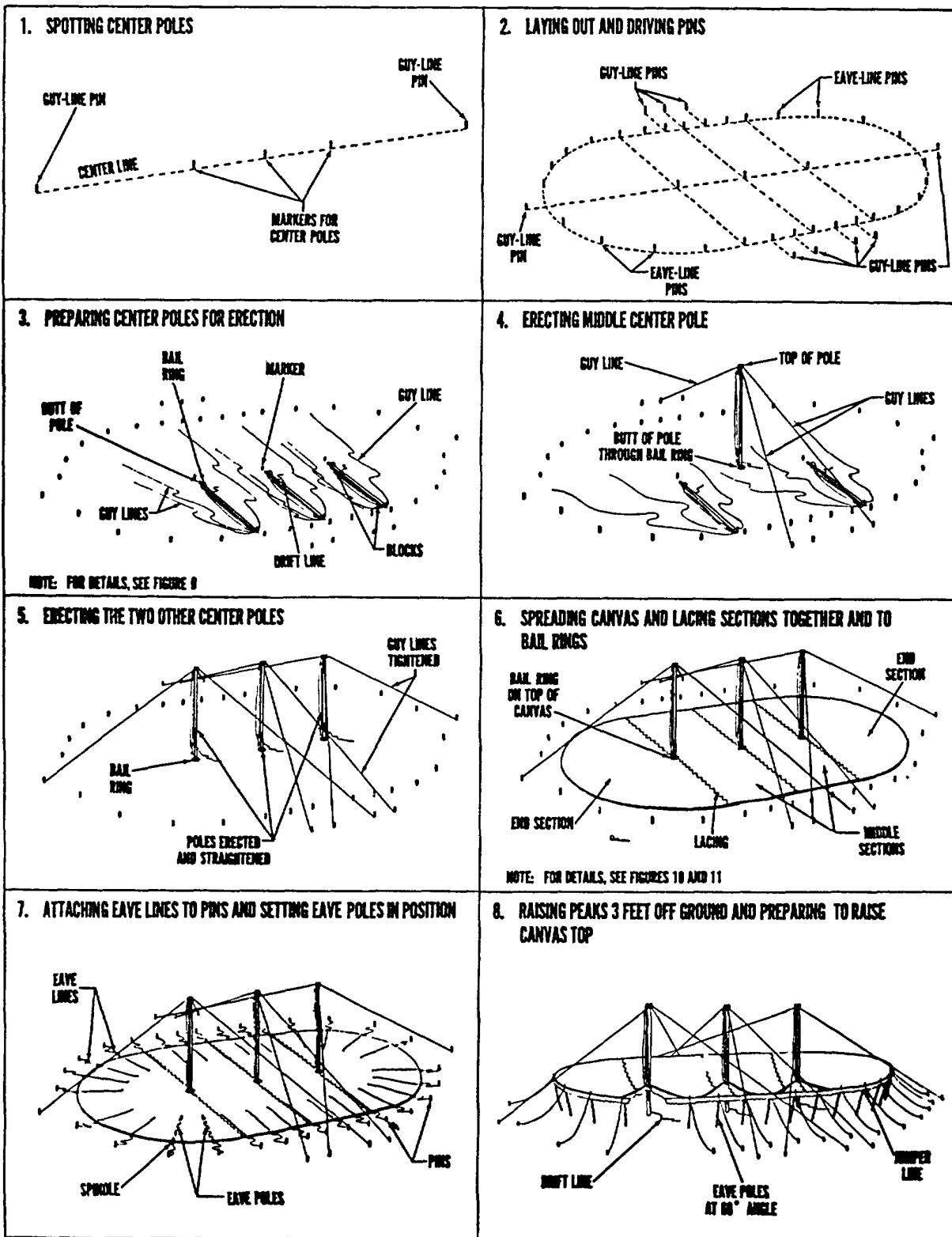

ME 8340-222-10/2-6 ①

Figure 2-6. Steps in pitching tent, assembly, M-1942. (Sheet 1 of 2).

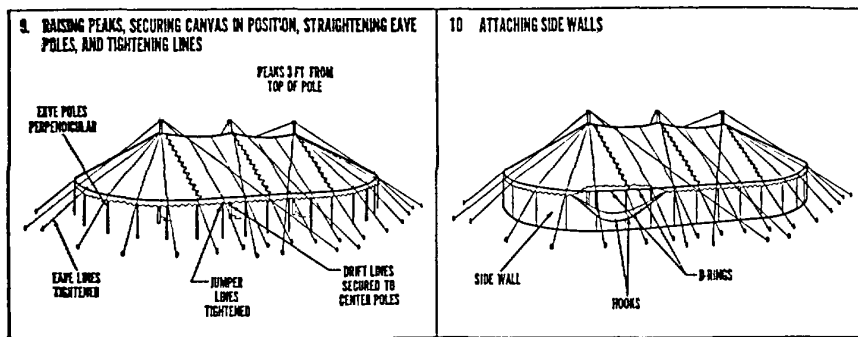

Figure 2-6. Steps in pitching tent, assembly, M-1942. (Sheet 2 of 2)

c. Laying Out and Driving Pins (2, fig. 2-6).

(1) *Eave-line pins.* Lay out and drive the 30 eave-line pins according to ground plan. Make sure that they are driven vertically and that the top of each pin is no more than 10 inches from the ground. The 27-foot extension cloth lacing line can be used as an aid in laying out the eave-line pins of the end sections.

(2) *Guy-line pins.* Lay out and drive guy-line pins according to ground plan. There are nine guy-line pins, three for each center pole.

d. Preparing Center Poles for Erection (3, figs. 2-6 and 2-7).

(1) Place the three center poles on the ground on one side of tent area. The poles should be perpendicular to the eave-line pins, and the butt end of each pole should be at a pole marker.

(2) Attach three main guy lines and one set of block and tackle to ferrule at top end of each pole. Lash drift line of block and tackle to pole, with single block 2 or 3 feet from butt end of pole. Place a bail ring assembly around butt end of each pole.

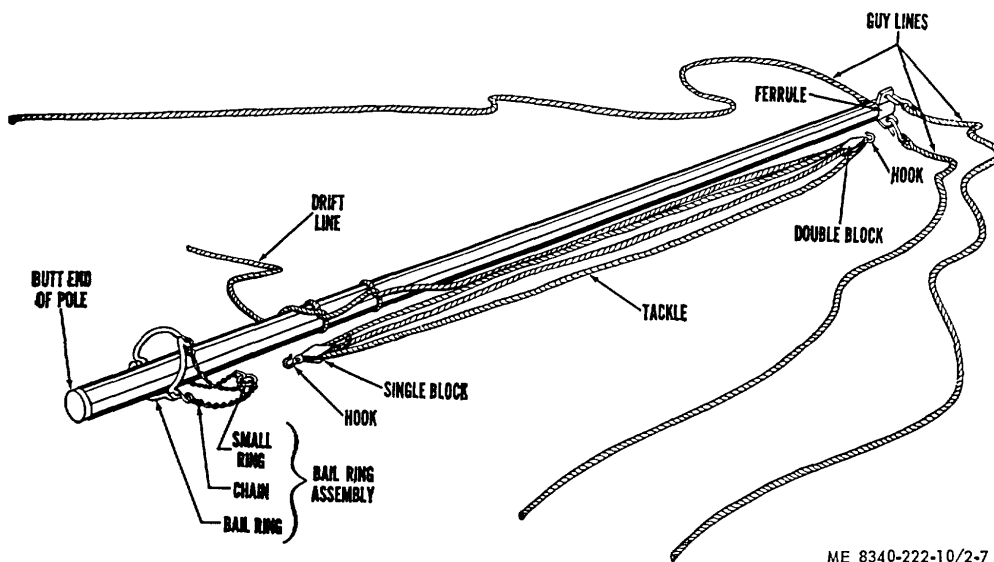

Figure 2-7. Preparing center pole for erection (tent, assembly, M-1942)

e. *Erecting Middle Center Pole* (4, fig. 2-6). One man stands at the butt end of the middle center pole, one man at the top end of the pole, and one man at the end of each of the three guy lines. One of these guy lines leads to the outside pin on a line at right angles from the center point of the long

dimensional line of the tent layout (fig. 2-5). This places the man holding the line directly in line with the man at the butt end of the pole. The man at the butt end of the pole keeps the pole in position with the marker by holding it with his foot. Be sure that the butt end of the pole is through

the bail ring. The man at the top end raises the pole and walks towards the butt end. The man holding the center guy line assists by maintaining a taut line as the pole is raised. After the pole reaches such a height that it might swing off center, the men holding the other two guy lines spread out slowly to keep the pole balanced until it is in a perpendicular position. Then the guy lines are attached to the pins indicated on the ground plan.

f. *Erecting the Other Two Center Poles* (5, fig. 2-6). The other two center poles should be erected as described in (4) above, except that one guy line leads to the outside pin on the direct center line of the long dimension of the tent layout. After poles have been erected, straighten them, and remove marker stakes. Tighten all center pole guy lines.

g. *Spreading Canvas and Lacing Sections Together and to Bail Rings* (6, fig. 2-6).

(1) Unfold the two middle sections and the two end sections. Spread sections on ground in position on tent area around the three center poles.

(2) Join sections from ridge to eave reinforcement line by chainlacing becket through grom-

nets, securing the last becket through the last grommet with a knot (1, fig. 2-8).

(3) Secure eave corners of sections together by lashing tieline through thimble on eave corner of one section and through thimble on eave corner of the other section (2, fig. 2-8).

(4) Pull extension cloth over chain lacing, lace extension cloth lacing line diagonally through ring chapes, and tie end of line through eave corner thimbles (2, fig. 2-8).

(5) Attach hooks on single blocks to small rings of bail ring assemblies off the ground about 1 foot (fig. 2-9).

(6) Secure sections on tent together at neck by lashing tieline on each side of neck through thimble of one section and through thimble of the other section (fig. 2-9).

(7) Fasten thimbles at necks of sections to bail rings by lacing neck lacing lines of two sections around bail ring and through thimbles (fig. 2-9).

(8) Unlash drift lines and put ends of lines through bail ring assemblies close to poles (fig. 2-9).

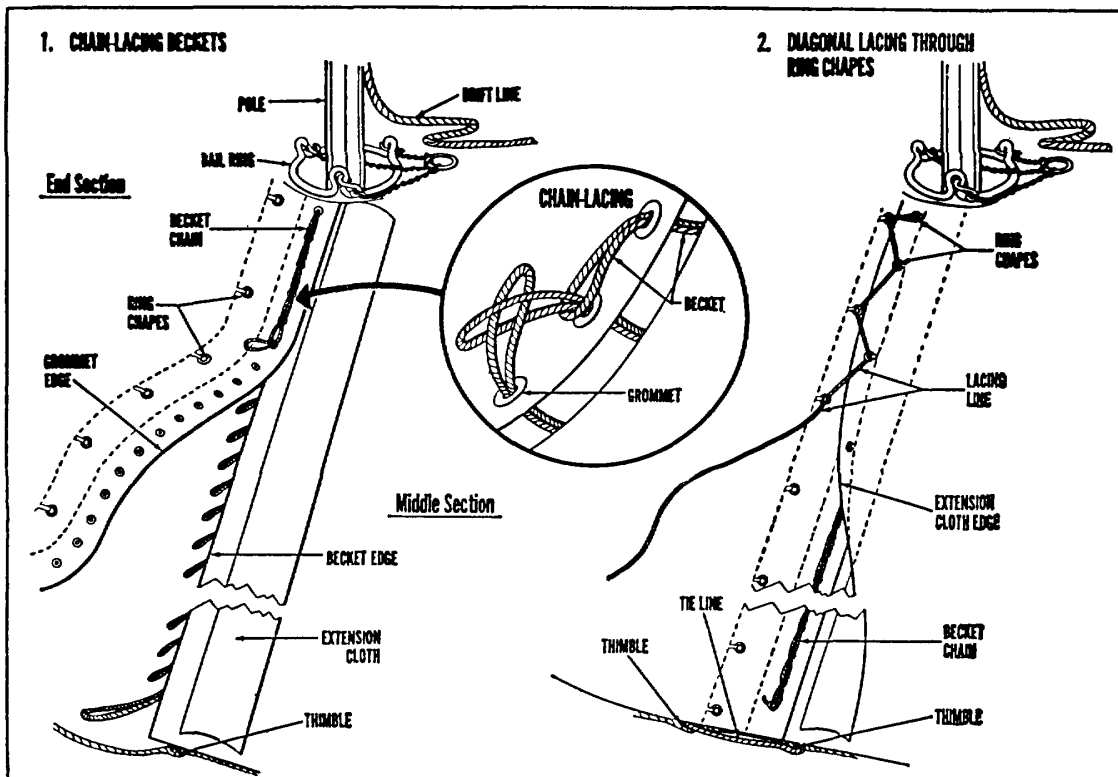

ME 8340-222-10/2-8

Figure 2-8. Steps in lacing top sections together (tent, assembly, M-1942).

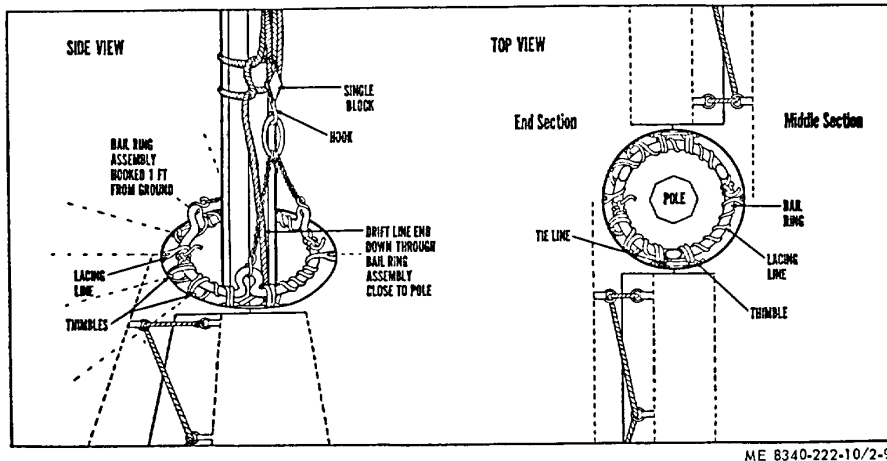

Figure 2-9. Lacing sections to bail rings, (tent, assembly, M-1942)

h. Attaching Eave Lines to Pins and Setting Eave Poles in Position. (7, fig. 2-6).

(1) Attach, with two half hitches, all eave lines to pins approximately 2 feet in from the end of each line.

(2) Raise canvas at eave and slide butt end of eave poles toward a center pole. Insert spindle of eave poles through leather reinforcements at point where eave lines are attached to canvas.

i. Raising Peaks 3 Feet Off Ground and Preparing to Raise Canvas Top (8, fig. 2-6).

(1) Going under canvas to center poles, raise peaks of tent about 3 feet off the ground by pulling drift lines. Lash drift line to center poles, making sure that drift line of each block and tackle assembly is inside bail ring and next to center pole (fig. 2-9).

(2) Set eave poles to form an angle of about 60° with the ground, with butt of each pole pointing toward, and in line with, butt of nearest center pole.

(3) Fasten jumper line at eave of canvas to each eave pole with two half hitches.

(4) Partly tighten all eave lines.

j. Raising Peaks, Securing Canvas in Position, Straightening Eave Poles, and Tightening Lines (9, fig. 2-6).

(1) Raise peaks with drift line of block and tackle to within 3 feet of top of each center pole. The three peaks of the tent should be raised at the same time.

(2) Straighten all eave poles to a perpendicular position and tighten all lines as much as possible to eliminate wrinkles in tent roof. Lines are tightened or loosened by readjusting the two half hitches on each guy and eave line near the pin; there are no tent slips used with the assembly tent.

(3) Secure drift lines firmly to center poles.

k. Attaching Sidewalls (10, fig. 2-6). Attach side-

walls by hooking wall hooks on top of sidewalls through D-rings attached to top sections of tent.

2-6. Striking Assembly Tent M-1942

NOTE

The tent can be struck by nine men in approximately 60 minutes.

a. Checking Center Pole Guy Lines. Check center pole guy lines, making sure that they are hooked in ferrule at top of center pole and are taut.

b. Detaching Sidewalls. Detach sidewalls by unhooking wall hooks from D-rings.

c. Adjusting Eave Poles. Slant butts of eave poles towards butts of center poles at a 60° angle with the ground. If weather is calm, untie eave pole jumper lines; do not untie jumper lines in a high wind.

d. Letting Down Peaks. Let peaks down to ground level by releasing drift lines, making sure that entire canvas area is in such a position that when sections are unlaced there will be little difficulty in folding them.

e. Removing Eave Poles. Remove all eave poles.

f. Removing Pins. Remove all eave line pins.

g. Unlacing Sections. Unlace sections of tent, remove from beneath center poles, and separate for folding into separate bundles.

h. Striking Center Poles. Strike center poles. To strike a center pole, two men stand at butt end of pole and one man at end of each guy line. Untie guy lines from pins. The men holding the ends of the guy lines then walk slowly toward the center of the tent area, keeping the lines taut to prevent the pole from swaying. One of the men at the butt end of the pole walks slowly forward with the pole, easing it gradually to the ground, while the other man at the butt end of the pole steadies it.

2-7. Folding Assembly Tent M-1942

NOTE

The tent can be folded and placed into six covers by nine men in approximately 20 minutes.

a. *Folding Middle Sections.* (1, fig. 2-10). Fold each of the two middle sections in half along the long dimensions and then in half again. Then, in 2-1/2-foot folds, fold ends toward center.

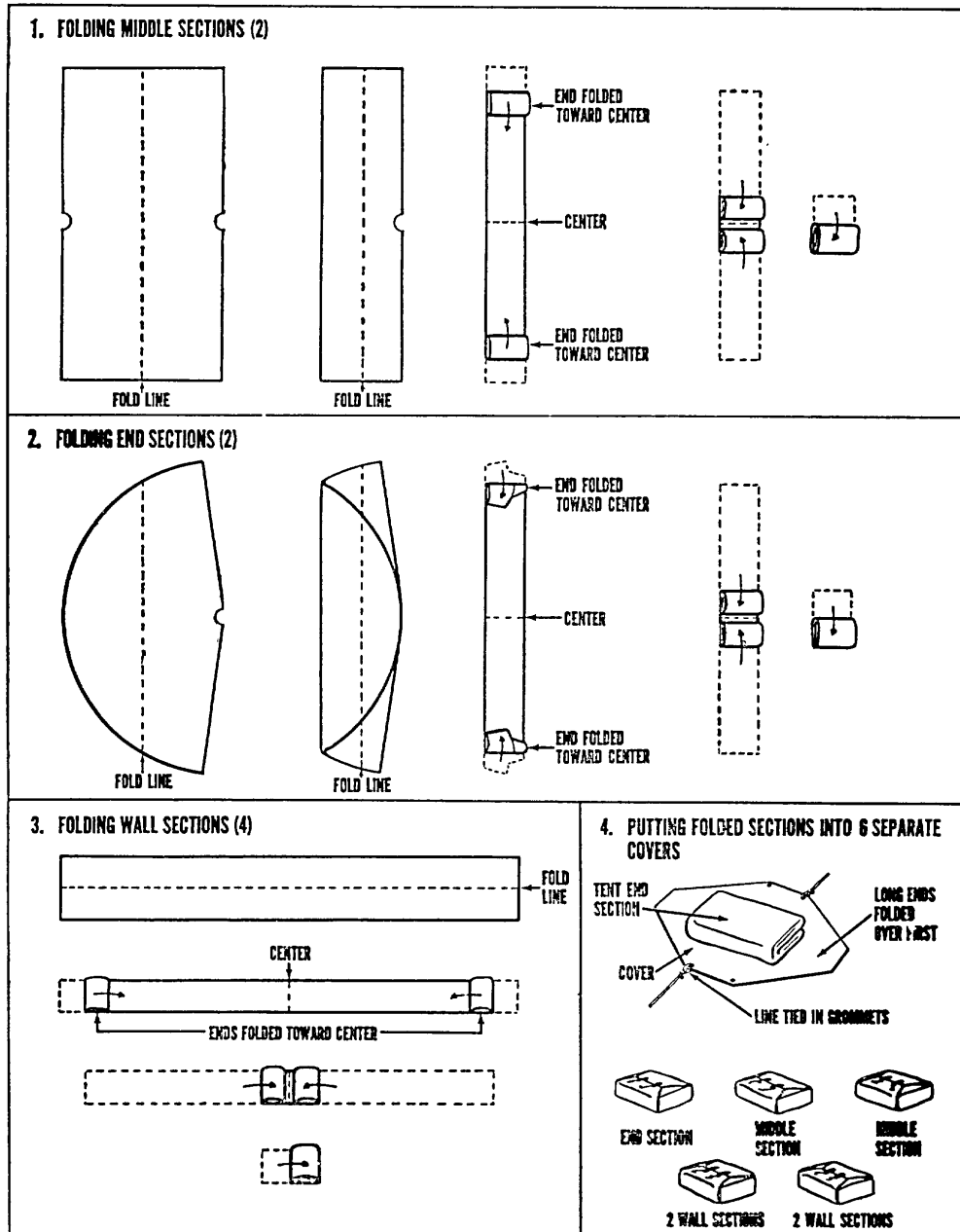

ME 8340-222-10/2-10

Figure 2-10. Steps in folding tent, assembly, M-1942

b. *Folding End Sections* (2, fig. 2-10). Fold each of the two end sections in half along the long dimensions and then in half again. Then, in 2½a-foot folds, fold ends toward center.

c. *Folding Wall Sections* (3, fig. 2-10). Fold each of the four wall sections in half along the long dimension. Then, in 2½a-foot folds, fold ends toward center.

d. *Putting Folded Sections Into Six Separate Covers* (4, fig. 2-10). Put folded sections into six separate covers. Place each middle and end section in a separate cover; place two wall sections in a separate cover. Fold flaps stretcher bearers passage without emitting light.

e. *Windows*. The tent has three 24-inch square window sashes, made of flexible translucent material. The sashes are inserted in window openings and held in place by snap fasteners. Canvas flaps cover the window during blackouts.

f. *Ventilation*. The tent is ventilated by an opening near the top of the rear end section. The ventilator has an inside duct, which may be closed by a tie cord. The ventilator hood is of the fixed type, constructed with a stiffener inserted in the hem to keep it extended out from

the ventilator opening. For additional ventilation, the sidewalls can be rolled up and the sidewall screens attached.

g. *Heating*. The tent is heated by an M-1941 tent stove. There is a stovepipe opening built in the top of the tent near the rear center upright pole. When not in use, the opening can be protected by a canvas flap.

h. *Liner*. A liner is provided with the tent. The liner can be attached to the tent to insulate it against heat or cold. The liner, when attached, covers only the main part of the tent; it does not cover the vestibule.

i. *Cover*. The tent is provided with a cover for use when it is in storage or is being transported.

2-8. Erecting (Pitching) Command Post Tent (M1945)

NOTE

The command post tent can be pitched by five men in approximately 20 minutes.

a. *Ground Plan*. Before pitching tent, study the ground plan carefully (fig. 2-11).

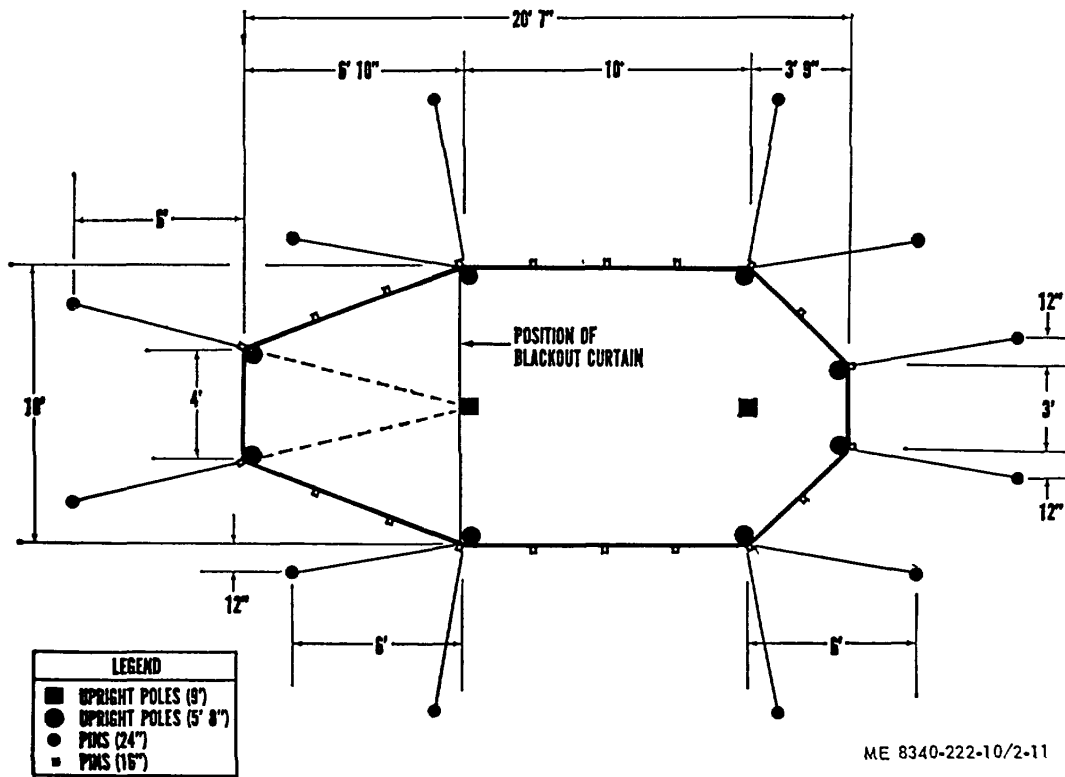

ME 8340-222-10/2-11

Figure 2-11. Ground plan of tent, command post, M-1945

b. Pitching Tent.

(1) Spread tent on ground with eave corners matching bottom corners.

(2) Drive a 16-inch pin at each of the eight tent corners. Attach a footstop to each of the four corner pins at front and rear of tent. At each of the four side corners, attached two footstops to one pin (1, fig. 2-12).

(3) Drive the twelve 24-inch pins according to ground plan.

(4) Attach guy lines loosely to long pins.

(5) Remove corner footstops from 16-inch pins, insert eave poles through eave grommets, and tighten guy lines until poles are vertical (3).

(6) Raise tent ridge by inserting spindle of a 9 foot pole through hole in metal plate and grommet at ridge at front of tent, and spindle of the other 9 foot pole through hole in metal plate and grommet in other end of ridge (4).

(7) Secure jumper lines to center poles and to eave poles with two half hitches (5).

(8) Reattach the 12 corner footstops to the 8 corner 16-inch pins. Drive the remaining twelve 16-inch pins and attach footstops to them.

(9) Tighten all guy lines.

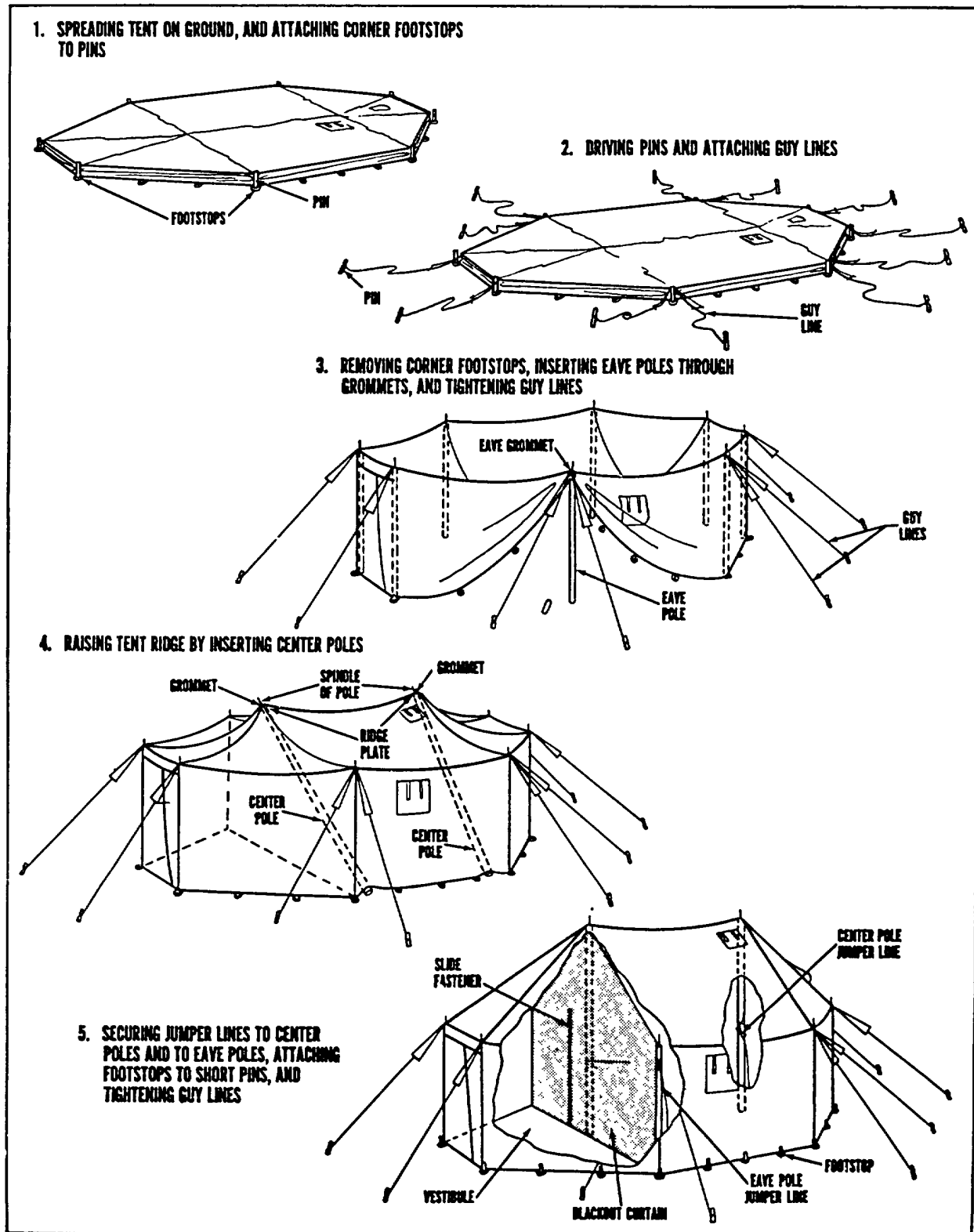

ME 8340-222-10/2-12

Figure 2-12. Steps in pitching tent, command post, M-1945

c. Attaching Liner to Tent.

(1) Unroll liner so that stovepipe and window openings match those of tent (1, fig. 2-13).

(2) Raise butt end of rear center pole and place it through hole in liner; run liner hoisting lines up poles through bull's-eyes at tent ridge (2).

(3) Hoist liner up to top of tent and secure lines to center poles (3).

(4) Fasten liner to eave corners of tent by tying tie tapes of liner to triangular hooks of tent (4).

(5) Tie tie tapes at stovepipe opening of liner to corresponding tie tapes at stovepipe opening of tent. Tie tie tapes at side of liner at eave to corresponding tie tapes at sides of tent at eave (5).

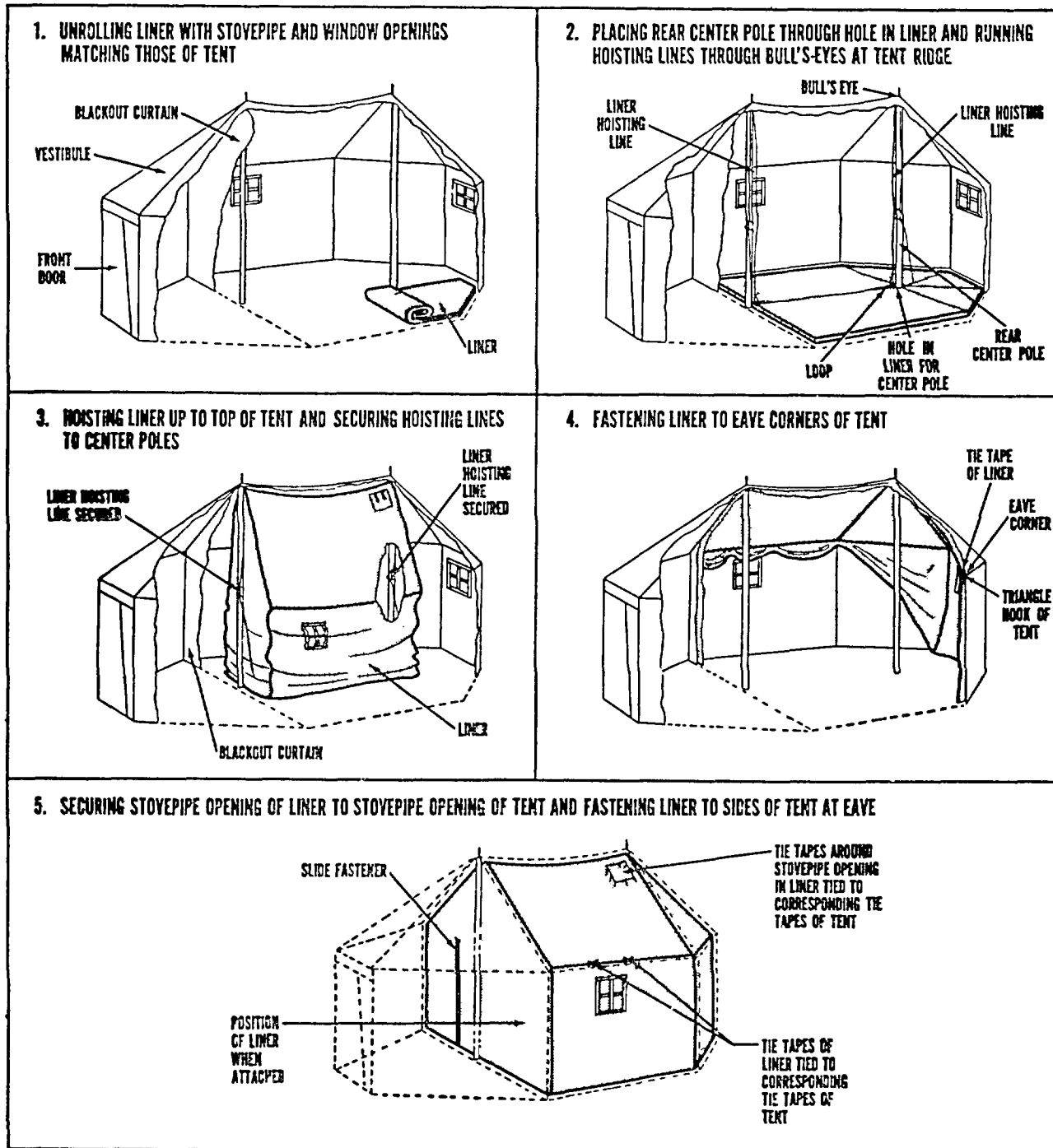

ME 8340-222-10/2-13

Figure 2-13. Steps in attaching liner to tent, command post, M-1945

d. *Attaching Screens to Sidewalls (fig. 2-14).* Remove footstops from sidewalls, open slide fasteners at corners, and roll up sidewalls and liner of tent and tie them with tie tapes near eave reinforcement. Then place a screen between lugs at each side of tent, aligning grommets on screen with grommets on lugs. Run the 13-foot rope, attached to a top corner of screen, through aligned grommets of screen and lugs at the top, securing with a knot at the last set of aligned grommets. In the

same manner, run the 8-foot rope, attached to each side of screen, downward through aligned grommets of screen and lugs, securing with a knot at the last set of aligned grommets. Fold screens at bottom so sod cloths are on ground inside tent. Fasten footstops that were removed from sidewalls to grommets at bottoms of screens, and attach footstops to the 16-inch pins.

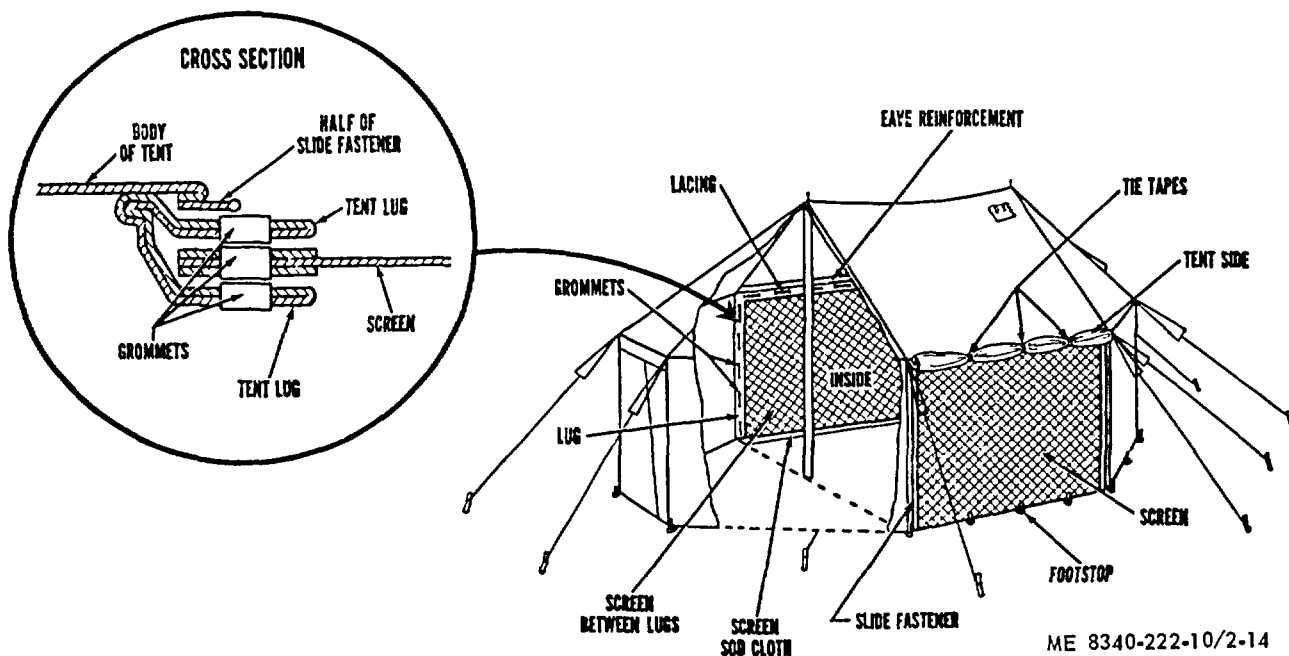

Figure 2-14. Attaching screens to sidewalls of tent, command post, M-1945.

2-9. Striking Command Post Tent (M-1945)

- a. Remove screens, and lower sidewalls of tent.
- b. Loosen liner hoisting lines, and untie tapes fastening liner to tent.
- c. Remove liner.
- d. Remove all footstops from 16-inch pins.
- e. Loosen all guy lines and remove center poles.
- f. Remove all 5-foot 8-inch eave poles.

- g. Remove all guy lines from 24-inch pins.
- h. Remove all pins.

2-10. Folding Command Post Tent (M-1945)

- a. Fold tent at ridge, with tent laid out flat one side on top of the other, sod cloth and vestibule door flaps extended, and blackout curtain folded neatly one half on top of the other half (1, fig. 2-15).

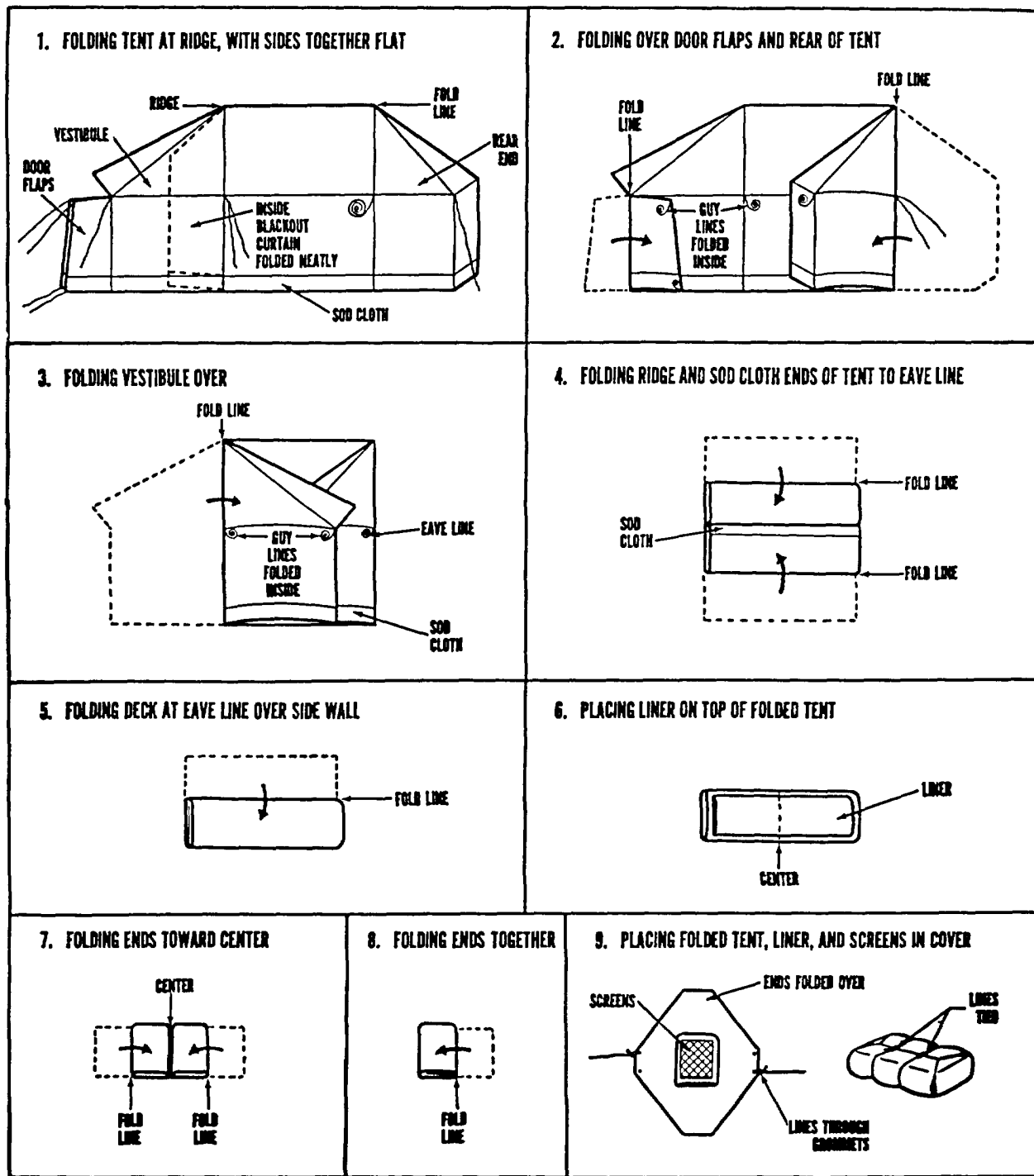

ME 8340-222-10/2-15

Figure 2-15. Steps in folding tent, command post, M-1945

b. Fold door flaps over on top of vestibule, then fold rear of tent over body of tent, the fold line extending from rear ridge plate down along rear body slide fasteners (2). Fold guy lines inside folded tent.

c. Fold vestibule over body of tent, the fold line extending from front ridge plate down along front body slide fasteners (3).

d. Fold both the ridge end of tent and the sod cloth end of tent to the eave line (4).

- e. Fold deck of tent to eave line over sidewall. Place exposed guy lines on folded tent (5).
- f. Place liner, folded in the same way as the tent, on top of tent (6).
- g. Fold ends of folded tent and liner toward center (7).
- h. Fold the two ends together (8).
- i. Place folded tent and liner in cover; place screens, each folded in fourths, on top of folded tent and liner; close cover, and tie with the two tielines (9).

2-11. Erecting (Pitching) Lightweight Tent (M-1950)

NOTE

The lightweight tent can be pitched by five men in approximately 15 minutes.

- a. *Ground Plan.* Before pitching the tent, study the ground plan carefully (fig. 2-16).

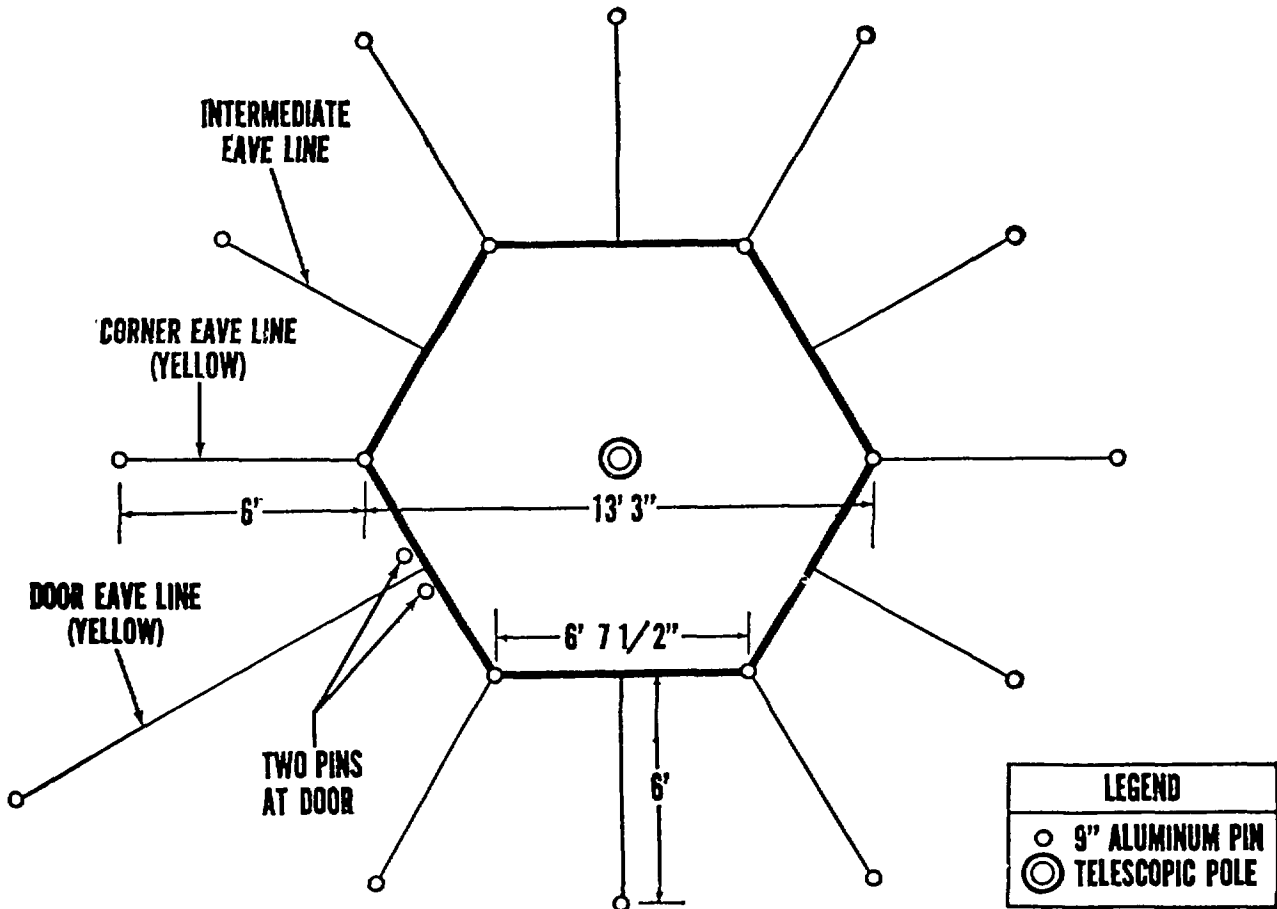
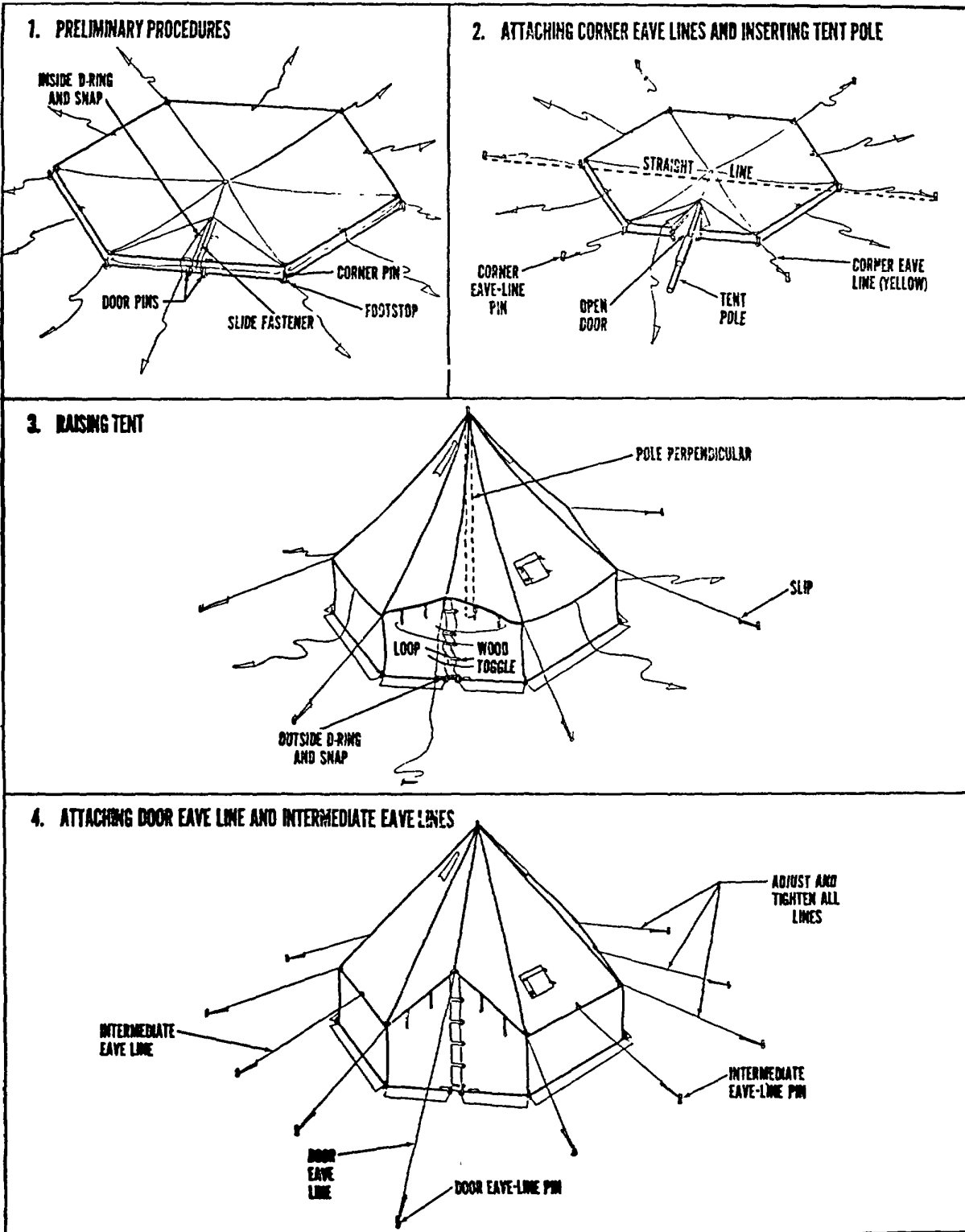

Figure 2-16. Ground plan, lightweight tent (M-1950).

- b. *Preliminary Procedures* (1, fig. 2-17).
 - (1) Spread tent on ground. Check to see if liner is in place; usually it is not in place in a new tent. If liner is not in place, spread it out beneath tent.

- (2) Secure D-ring to snap inside door.
- (3) Close slide fastener in door.
- (4) Drive six corner pins and two door pins and attach footstops to pins.



ME 8340-222-10/2-1

Figure 2-17. Steps in pitching tent, hexagonal, lightweight, M-1950

c. *Attaching Corner Eave Lines and Inserting Tent Pole (2, fig. 2-17).*

(1) Drive pins about 6 feet from corners of tent and attach corner eave lines to pins. Pins on opposite sides of tent should be in a straight line.

(2) Open door and push pole, extended to 8 feet 6 inches, under tent.

(3) Insert spindle of pole through grommet in peak of liner and through handworked ring in peak of tent.

d. *Raising Tent (3, fig. 2-17).*

(1) With one man inside the tent, close inside and outside D-rings and snaps on door; close slide fastener.

(2) Fasten loops to wood toggles on door.

(3) Raise tent and liner; place butt of tentpole in center of tent area.

e. *Attaching Door Eave Line and Intermediate Eave Lines (4, fig. 2-17).*

(1) Stake door eave line far enough to hold door vertical.

(2) Stake intermediate eave line pins.

(3) Attach the five intermediate lines to pins.

(4) Adjust and tighten all lines.

f. *Propping Up Door Eave Line.* The door eave line can be propped up by placing the line over an improvised pole (tree branch or other object higher than the door entrance) at a distance of about 5 feet in front of the door and then staking the line out to a pin. This keeps the door from sagging, makes the slide fastener work better, makes the tent easier to get into and out of, and gives the tent greater stability.

g. *Fastening Liner.* Fasten liner in place by inserting wire toggles, which are secured to tent, into grommets set in liner. Allow approximately 2 inches between tent and liner for insulating purposes. Tie tapes around stovepipe opening in liner to corresponding tapes around stovepipe opening in tent to keep stovepipe opening in place. The 35-foot sock line is threaded through the eyes of the toggles at the eave line and tied to the toggle at each corner of the door. The 30-foot sock line is threaded through the eyes of the next row to toggles and the two ends are tied in a square knot. The 19-foot sock line is threaded through the eyes of the remaining row of toggles and the ends are tied in a square knot.

2-12. Striking, Lightweight Tent (M-1950)

a. Loosen liner tie tapes.

b. Loosen door eave line.

c. Remove all footstop pins.

d. Loosen all eave lines and remove all eave line pins.

e. Remove tentpole, and telescope pole to its shortest length.

f. Remove liner only if repairs are needed.

2-13. Folding, Lightweight Tent (M-1950)

a. *Folding Tent (fig. 2-18).*

(1) Engage snap into D-ring inside door and close door slide fasteners.

(2) Spread tent on ground and locate stovepipe opening panel on top fold. Grasp corner eave line (to the right of stovepipe opening) and pull out corner of panel. Then coil intermediate eave line and corner line neatly on extended panel (1).

(3) Reaching to the left, grasp corner eave line (to the left of stovepipe opening) and pull the second panel to the right, making an accordion fold (2).

(4) Fold remaining panels in the same manner, having six folds in all. As each fold is completed, coil intermediate eave lines, corner eave line, and door eave line neatly between folds (3).

(5) Coil on top of folded tent panels the last remaining intermediate eave line and corner eave line (4).

(6) Fold snow cloth over sidewalls of tent. Fold peak of tent to edge of snow cloth (5).

(7) Fold short side of tent toward center to make a rectangle of the tent (6).

(8) Roll or fold tent to the smallest possible size, and place tent on cover. Place nested pins and telescoped pole into pocket of cover (7).

(9) Close cover, securing it with straps and loops. Care should be taken that flaps are tucked neatly inside cover.

b. *Folding Liner.* Ordinarily the liner is not removed from the tent. When necessary, the liner can be folded separately in the same manner as the tent. After the liner is folded it can be placed inside the cover with tent, pins, and pole.

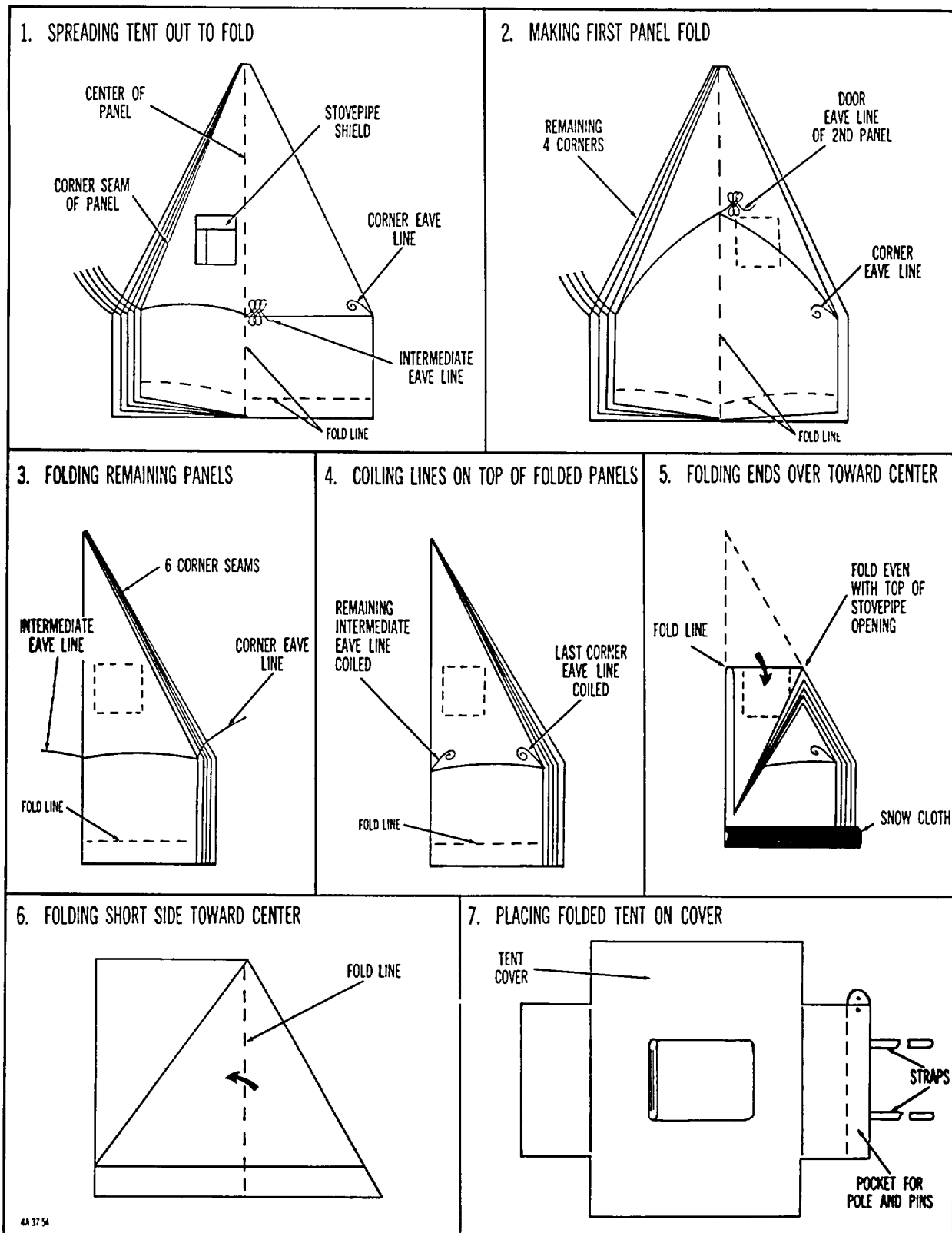

4A 37 54

ME 8340-222-10/2-18

Figure 2-18. Steps in folding tent, hexagonal, lightweight, M-1950

Section II. OPERATIONS UNDER UNUSUAL CONDITIONS

2-14. Using the Tent in Cold Climates

a. Before selecting a campsite on snow-covered ground, prod surface with an ice axe or ski pole to see whether snow conceals any crevices. It may be impossible to find an area entirely without crevices, but it is possible to avoid accidents by knowing where they are.

b. When an adequate site on snow has been found pack snow hard by stamping on it with skis or snowshoes, or better still, shovel top snow off until firm snow is found below.

c. Pitch tent so that entrance is not directly downwind. If the tent is pitched on snow with the entrance directly downwind, the entrance may become blocked, since snow tends to pile up in the lee of any object.

d. If site is not temporary, dig tent into snow. This will provide better protection from the wind. In open terrain with a strong wind, it may be necessary to build a snow wall on the windward side of the tent to protect it from the wind; thus the tent is easier to heat, is less likely to blow down. Leave some space between sides of tent and snow wall to have room to shovel out snow that may drift into tent.

e. When a tent is pitched on a slope, a horizontal platform should be formed. The snow which is removed may be packed around the outer edge of the platform to widen the space for the tent.

f. High winds, common in cold weather regions, require that tents be anchored securely. The tent pins may not provide sufficient anchorage. Arctic tents have snow cloths sewed along the bottom edge of tent walls. When an arctic tent is set up, snow cloths should be flat on the ground outside the tent. Place snow, snow or ice blocks, stones, logs, or other heavy objects on the cloths to help anchor the tent.

g. Do not attempt to drive tent pins into hard, frozen ground if the force required is excessive. Instead, chop small holes into the ground, insert tent pins into holes, and fill holes with a slush or water; in a short time the tent pins will be firmly anchored. When removing pins from frozen ground, always chop them out; never hammer them sideways to break them loose.

NOTE

In areas where winter conditions prevail the use of the 12 inch steel tent pins (NSN 8340-00-823-7451) is required rather than the 9 inch aluminum pins furnished with erection kits. Attempts to install the aluminum pins under winter

conditions will only result in bending and breaking the pins.

h. Snow carried into a tent will melt and wet sleeping bags and clothing. The following precautions should be taken to keep snow out of tents:

(1) Each man must take care to brush all snow from his clothing and boots before entering a tent.

(2) One man should enter the tent first and take the sleeping bags, packs, and other articles from the other man after the items have been brushed off completely.

2-15. Using the Tent in Wet Climates

The following instructions supplement the instructions given in paragraph 1-1 b.

a. When possible, erect the tent on a mound which slopes in all directions.

b. If the tent is erected in flat terrain of heavy soil or clay, dig a trench around the tent. To carry water from the trench, dig an outlet ditch from the trench to the lowest point in the area.

NOTE

When the tent is set up on a very sandy soil, which absorbs water as fast as it falls, or when it is located on a mound which slopes off in all directions, a trench may not be necessary.

c. When digging trench, throw dirt away from the tent; never throw it against the tent, for it will quickly rot the canvas. In most cases, do not dig trench more than 4 or 5 inches deep and in the shallowest place not over 3 inches.

NOTE

There should be enough slope in the trench so that the water will flow freely toward the outlet and not back up.

d. When there is possibility that water may flow to the trench from higher ground, dig a ditch that will divert the water before it can reach the tent.

e. Before the tent lines become watersoaked, loosen them sufficiently so that when they shrink they will not pull the tent pins from the ground or tear the tent body. However, they must remain slightly taut.

CHAPTER 3

MAINTENANCE INSTRUCTIONS

Section I. LUBRICATION INSTRUCTIONS

The slide fasteners are the only items on the tent which require lubrication. When the sliding member of the fastener is difficult to move, apply stick form lubricant

(FSN 9150-999-7548) to the metal slides of the fasteners.

Section II. PREVENTIVE MAINTENANCE CHECKS AND SERVICES (PMCS)**3-1. General**

Preventive maintenance checks and services are the minimum inspections which are performed daily to insure that defects may be discovered and corrected before they result in serious damage to or failure of the equipment. When defects are discovered during operation / use of the equipment, they must be corrected as soon as operation / use has ceased. If continued operation / use would result in damage to the equipment,

the defects must be corrected at once. All deficiencies and shortcomings that are discovered and all action that is taken will be recorded on DA Form 2404 as soon as possible.

3-2. Preventive Maintenance Checks and Services.

The preventive maintenance checks and services listed in table 3-1 will be performed in the sequence in which they are numbered.

Table 3-1. Preventive Maintenance Checks and Services

Interval and sequence no.		Item to be inspected-procedure	Work time (M/H)
D ¹	W ¹		
1		ANCHORING COMPONENTS Check that pins are in place, in serviceable condition, at all required positions per ground plan, and that all lines are properly connected and adjusted at the slips. Replace broken wood or damaged metal pins.	.20
2		SUPPORT COMPONENTS Inspect wood poles for cracks, or breaks. Inspect metal poles for bends, or missing hardware. Replace defective poles.	.10
3		TENT FABRIC (OUTER SKIN) Inspect fabric for rips, tears, holes, cuts, broken or missing stitching, mildew, signs of extreme wear, or any other defect. Report all defects to organizational maintenance personnel.	.20
4		WEBBING OR SEAMS Inspect all webbing and seams for broken or loose stitching. Mark and report all defects noted.	.10
5		TIE TAPES Check that all tie tapes are present, in serviceable condition, and are being used properly.	.10
6		SLIDE FASTENERS Check that all slide fasteners at corners, doors, and windows are securely sewed to fabric, that slider moves properly, and that there are no missing scoops or stops. Lubricate a sticking slide, or one that moves with difficulty, Report a defective slide to organizational maintenance.	.05
7		HARDWARE Check that all D-rings, round rings, grommets, ridge plates, tent slips, fairleads, eyes, and snaphooks are present, in serviceable condition, and are in proper use.	.15
8		WINDOWS Inspect windows for torn screen, defective window pane, inoperable slide fastener, missing tie tapes, or torn or missing stitching. Lubricate a sticking slider. Mark and report other defects to organizational maintenance.	.05
9		LINER AND VESTIBULE (WHEN IN USE) Perform checks 1 through 7 above for liner or vestibule when in use.	.05

¹D-Daily. W-Weekly.

Section III. TROUBLESHOOTING

3-3. General

a. This section contains troubleshooting information for locating and correcting most of the troubles which may develop in the tent (10-man arctic, M-1942 assembly, M-1945 command post, or M-1950 lightweight).

b. This manual cannot list all malfunctions that may occur, nor all tests or inspections and corrective actions.

If a malfunction is not listed or is not corrected by listed corrective actions, notify your supervisor.

3-4. Troubleshooting

In table 3-2, each malfunction listed is followed by inspections which will help you to determine probable causes and corrective actions to take. You should perform the inspections and corrective actions in the order listed.

Table 3-2. Troubleshooting

MALFUNCTION	TEST OR INSPECTION	CORRECTIVE ACTION
1. SLIDE FASTENER HARD TO OPERATE	Step 1. Inspect for dirt or corrosion Step 2. Check for crushed slider.	Clean by using a soft bristle brush, then lubricate Report to organizational maintenance
2. RIDGE PLATE (OR RIDGE POLE) DOES NOT FIT SQUARELY ON UPRIGHT	Check for bent or missing spindle.	Straighten spindle or replace upright pole
3. EAVE AND CORNER GROMMETS RIPPING OUT WITH REGULARITY	Step 1. Inspect for old and worn fabric Step 2. Check tightness of lines in wet weather. Step 3. Check lines for looseness during windy weather	Replace tent. Loosen at tent slips in wet weather. Tighten at tent slips more frequently during windy periods
4. TENT PINS PULLED UP	Check for tightness during heavy rains	Reset pins with poles angled slightly towards tent. Adjust lines at tent slips more frequently.
5. TENT LEAKING	Step 1. Check for hole in fabric. Step 2. Inspect for deterioration of weather proofing compound.	Mark, and report to organizational maintenance for patching at earliest opportunity. Report defect to organizational maintenance

Section IV. MAINTENANCE PROCEDURES

3-5. Protection of Tent Against Damage

a. *General.* Probably the greatest amount of damage to tentage is caused by carelessness, such as forgetting to loosen the lines when it starts to rain, not bothering to use spark arresters or draft diverters, adjusting lines carelessly, driving pins in a slipshod manner, or dragging tents over rough ground. To prolong the life and usefulness of tentage, the following rules should be observed:

(1) Pitch, strike, and fold tentage in the manner described in this manual. Do not try to take shortcuts unless you are sure no damage will be done.

To protect the top of the tent, fold the tent so that the sidewalls rather than the top of the tent will be exposed.

(2) Observe the utmost care when pitching and striking tent, making sure the material does not tear on protruding pins, overhanging branches, or other objects.

(3) Never drag tent along the ground or floor.

(4) Use all the necessary parts and accessories for the tent and use them for their intended purpose.

(5) Pack tent carefully for shipment. Some tents are issued complete with bag or cover. In this case, carry tent in bag or cover. When no bag or cover is issued, the tent is usually received wrapped in osnaburg or burlap. Save this material for rewrapping when the tent has to be moved again. Normally, tent should never be transported without a covering of some kind.

(6) Pack pins and poles separately from the tent itself except when tent instructions require them to be packed with the tent.

(7) Inspect tentage at frequent intervals to make sure that it is in serviceable condition. Particular attention should be given to seams, bindings, lines, and all places where strain is exerted. Be constantly on the lookout for

(a) Any evidence of mildew.

(b) Any foreign matter which may have collected on the tent.

(c) Small rips and holes, splitting of seams, grommets which have become loose, lines which are beginning to rot, or anything else which does not appear to be in normal condition.

b. Protection Against Rain.

(1) All tents are water repellent. However, rain causes tent canvas and lines to shrink, the shrinkage often becoming sufficient to tear the tent. Tents have been torn completely in two under such circumstances.

(2) Before tent lines become water soaked, they should be loosened sufficiently so that when they shrink they will not become tight enough to tear the tent. To compensate for shrinkage, eave and corner lines should have a free swing of approximately 18 inches at the middle of the line.

c. Protection Against Wind. In a strong wind, all lines should be tightened immediately, door entrances closed, walls secured to footstop pins, and all corners closed.

d. Protection Against Fire.

(1) Most tents are fire resistant. This does not mean that they will not burn; they usually do not burst into flame, but smolder and char.

(2) When using a stove in a tent, every precaution must be taken to avoid fires. Spark arresters or draft diverters must be installed and shields placed around stovepipe openings. All personnel should be well trained in building and maintaining stove fires and should be familiar with all fire regulations.

(3) Whenever possible, fire extinguishers containing water should be kept in the tent area.

e. Protection Against Mildew.

(1) Most tents are mildew resistant. This does not mean that they are not subject to mildew. Under warm and damp conditions, especially in tropical and jungle areas, tents may be ruined by mildew in a few days, if proper care is not taken.

(2) To prevent mildew, follow these rules:

(a) Never fold or roll tent when wet. Make doubly sure that the seams and edges of the tent, especially the bottom edge and the sod cloth, are dry.

(b) When transporting, keep pins and poles separate from tent, except when tent instructions require them to be packed with the tent. In the case of the latter, make sure the pins and poles are cleaned and dried before being placed with the tent.

(c) Keep tent clean at all times. If tent is pitched under trees, inspect the tent roof frequently to see if it is being harmed by drippings from branches or leaves. The growth of fungi and mold is caused to some extent by tree drippings, oils, greases, and starches which accumulate on tentage.

3-6. Protection of Pins, Poles, and Lines Against Damage

a. Pins. All wooden tent pins currently issued receive a wood-preservative treatment. Care should be taken in handling pins to see that they are not broken or otherwise damaged. In determining the serviceability of pins, look for cracks, splits, distorted ends, and broken or flattened points.

b. Poles. Care should be taken in handling tentpoles to see that they are not broken or otherwise damaged. In determining the serviceability of poles, look for cracks, splits, condition of metal joiners, and missing or bent spindles.

c. Lines. Lines should be inspected frequently. The stability and safety of the tent may depend on the condition of the various lines used. Deterioration in tent lines is of two kinds: physical and chemical. Physical damage is caused by surface wear or from internal friction between the fibers. Chemical damage is caused by exposure to weather conditions and acids. To prevent damage to tent lines, observe the following:

(1) Dry lines properly after exposure to dampness. Lines are best dried when hung loosely between two trees or other objects so that they do not come in contact with the ground.

(2) Keep lines clean. If lines become dirty, they should be washed in clean water and thoroughly dried. Grit from sand, mud, or other materials,

if allowed to remain and work into lines, will grind and wear the fibers.

(3) Protect lines from chemicals. Keep lines away from chemicals or their fumes, especially acids or alkalis. Drying oils, such as linseed oil, and paint will also damage lines.

(4) Slack off guy lines. When guy lines or other supports are exposed to the weather, slack them

off to prevent overstrain because of shortening from wetting.

(5) When wear is localized in a short section, periodical shortenings will present a new wearing surface.

(6) If a line becomes damaged, replace with a new line.

(7) Whip ends of lines to prevent raveling.

APPENDIX A
REFERENCES

Maintenance

DA Pam 738-750

The Army Maintenance Management Systems (TAMMS)

APPENDIX B

COMPONENTS OF END ITEM AND BASIC ISSUE ITEMS LISTS

Section I. INTRODUCTION

B-1. SCOPE

This appendix lists components of end item and basic issue items for the tent to help you inventory items required for safe and efficient operation.

B-2. GENERAL

The Components of End Item and Basic Issue Items Lists are divided into the following sections:

a. Section II. Components of End Item. This listing is for informational purposes only, and is not authority to requisition replacements. These items are part of the end item, but are removed and separately packaged for transportation or shipment. As part of the end item, these items must be with the end item whenever it is issued or transferred between property accounts. Illustrations are furnished to assist you in identifying the items.

b. Section III. Basic Issue Items. These are the minimum essential items required to place the tent in operation, to operate it, and to perform emergency repairs. Although shipped separately packaged BII must

be with the tent during operation and whenever it is transferred between property accounts. The illustrations will assist you with hard-to-identify items. This manual is your authority to request/requisition replacement BII, based on TOE/MTOE authorization of the end item.

B-3. EXPLANATION OF COLUMNS

The following provides an explanation of columns found in the tabular listings:

a. *Column (1)*-Illustration Number (Illus Number). This column indicates the number of the illustration in which the item is shown.

b. *Column (2)*-National Stock Number. Indicates the National stock number assigned to the item and will be used for requisitioning purposes.

c. *Column (3)*-Description. Indicates the National item name and, if required, a minimum description to identify and locate the item. The last line for each item indicates the FSCM (in parentheses) followed by the part number.

d. Column (4) - Unit of Measure (U/M). Indicates the measure used in performing the actual operational/maintenance function. This measure is expressed by a two character alphabetical abbreviation (e.g., ea, in, pr).

e. Column (5) - Quantity required (Qty rqr). Indicates the quantity of the item authorized to be used with/on the equipment.

**Section II. COMPONENTS OF END ITEM FOR TENT, ARCTIC, 10-MAN,
NSN 8340-01-059-4075; NSN 8340-00-262-3685**

(1) Illus Number	(2) National Stock Number	(3) Description, FSCM and Part Number Usable On Code	(4) U/M	(5) Qty Rqr	
	8340-00-262-3684	Tent, w/Cover and Liner (81349) MIL-T-12354	N/A	EA	1
	8340-00-188-8413	Pole, Tent, Telescopic: 4'9" to 9' long (81349) MIL-P-1716	N/A	EA	1
	8340-00-261-9749	Pin, Tent, Aluminum: 9" long (81349) MIL-P-501	N/A	EA	28
	8340-00-823-7451	Pin, Tent, Steel: 12" long (81349) MIL-P-501	N/A	EA	28
	8340-00-641-4358	Line, Tent, 40'6" lg MIL-T-12354	N/A	EA	1
	8340-00-252-6912	Line, Tent, 12'6" lg MIL-L-1709	N/A	EA	4
	8340-00-252-6913	Line, Tent, 12'6" lg MIL-L-1709	N/A	EA	2
	8340-00-262-3658	Line, Tent, 12'K6" lg MIL-L-1709	N/A	EA	6
	8340-00-205-2759	Slip, Tent Line MIL-S-1734	N/A	EA	18

*Steel tent pins are authorized for use in winter climatic conditions where the temperature falls below freezing.

Components of End Item for Tent, Assembly, Circus Type

NSN 8340-00-262-2877

(1) Illus Number	(2) National Stock Number	(3) Description, FSCM and Part Number Usable On Code	(4) U/M	(5) Qty Rqr	
	8340-00-082-5738	Pole, Tent, Wood, 8'3" long (81349) MIL-P-549	N/A	EA	30
	8340-00-241-8183	Pole, Tent, Wood, 21' Long (81349) MIL-P-549	N/A	EA	3
	8340-00-261-9752	Pin, Tent, Wood, 36" long (81349) MIL-P-2383	N/A	EA	39
	8340-00-266-6780	Tent Section, End (81349) MIL-T-1110	N/A	EA	2
	8340-00-266-6781	Tent Section, Middle (81349) MIL-T-1110	N/A	EA	2
	8340-00-266-6782	Tent Section, Wall (81349) MIL-T-1110	N/A	EA	4
	8340-00-377-6606	Rigging Set (81349) MIL-T-1110	N/A	EA	1

**COMPONENTS OF END ITEM FOR TENT, COMMAND POST, M-1945
NSN 8340-00-269-1370**

(1) Illus Number	(2) National Stock Number	(3) Description, FSCM and Part Number Usable On Code	(4) U/M	(5) Qty Rqr
	8340-00-082-2167	Pole, Tent, Wood, 9' long (81349) MIL-P-549 N/A	EA	2
	8340-00-188-8405	Pole, Tent, Wood, 5'8" long (81349) MIL-P-549 N/A	EA	8
	8340-00-261-9750	Pin, Tent, Wood, 16" long (81349) MIL-P-2383 N/A	EA	20
	8340-00-261-9751	Pin, Tent, Wood, 24" long (81349) MIL-P-2383 N/A	EA	12
	8340-00-254-5358	Tent w/Cover Screen, and Liner, lines & slip liners N/A (81349) MIL-T-1111	EA	1

**COMPONENTS OF END ITEM FOR TENT, HEXAGONAL, LIGHTWEIGHT, M-1950
NSN 8340-01-026-6095**

(1) Illus Number	(2) National Stock Number	(3) Description, FSCM and Part Number Usable On Code	(4) U/M	(5) Qty Rqr	
	8340-00-269-1374	Tent, w/Cover, liner (81349) MIL-T-10035	N/A	EA	1
	8340-00-262-3700	Liner, Tent (81349) MIL-T-10035	N/A	EA	1
	8340-00-241-8435	Cover, Tent (81349) MIL-T-12354	N/A	EA	1
	8340-00-261-9749	Pin, Tent, Aluminum: 9" long (81349) MIL-P-501	N/A	EA	20
	8340-00-188-8413	Pole, Tent, Telescopic: 4'9" long to 9' long (81349) MIL-P-1716	N/A	EA	1
	8340-00-823-7451	Pin, Tent, Steel 12" long (81349) MIL-P-501	N/A	EA	20
	8340-00-252-6911	Line, Tent, 19' lg MIL-L-1709	N/A	EA	1
	8340-00-252-6910	Line, Tent, 35' lg MIL-L-1709	N/A	EA	1
	8340-00-252-2304	Line, Tent, 30' lg MIL-L-1709	N/A	EA	1
	8340-00-252-6912	Line, Tent, 12'6" lg MIL-L-1709	N/A	EA	5
	8340-00-252-6913	Line, Tent, 21'6" lg MIL-L-1709	N/A	EA	1
	8340-00-262-3658	Line, Tent, 12'6" lg MIL-L-1709	N/A	EA	6
	8340-00-252-2299	Line, Tent, 19" lg MIL-L-1709	N/A	EA	8
	8340-00-205-2759	Slip, Tent Line MIL-S-1734	N/A	EA	12

* Steel tent pins are authorized for use in winter climatic conditions where the temperature falls below freezing.

**Section III. BASIC ISSUE ITEMS FOR TENT, ARCTIC, 10-MAN,
NSN 8340-00-262-3685; NSN 8340-01-059-4075**

(1) Illus Number	(2) National Stock Number	(3) Description, FSCM and Part Number Usable On Code	(4) U/M	(5) Qty Rqr
	8340-01-176-6404	Kit, Lock Repair (81337) 5-4-1075/7/8/10 N/A	EA	1

**BASIC ISSUE ITEMS FOR TENT, ASSEMBLY, CIRCUS TYPE, M-1942
NSN 8340-00-262-2877**

(1) Illus Number	(2) National Stock Number	(3) Description, FSCM and Part Number Usable On Code	(4) U/M	(5) Qty Rqr
	8340-00-262-2397	Cover (81349) MIL-T-1712 N/A	EA	6

**BASIC ISSUE ITEMS FOR TENT, HEXAGONAL, LIGHTWEIGHT, M-1950
NSN 8340-01-026-6095**

(1) Illus Number	(2) National Stock Number	(3) Description, FSCM and Part Number Usable On Code	(4) U/M	(5) Qty Rqr
	8340-01-176-6404	Kit, Lock Repair (81337) 5-4-1075/7/8/10 N/A	EA	1
	8340-00-241-8435	Cover (81349) MIL-T-12354 N/A	EA	1

APPENDIX C**ADDITIONAL AUTHORIZATION LIST**

Section I. INTRODUCTION**1. SCOPE**

This appendix lists additional items you are authorized for the support of the tent.

2. GENERAL

This list identifies items that do not have to accompany the tent and that do not have to be turned in with it. These items are all authorized to you by CTA, MTOE, TDA, or JTA.

3. EXPLANATION OF LISTING

National stock numbers, descriptions, and quantities are provided to help you identify and request the additional items you require to support this equipment. The items are listed in alphabetical sequence by item name under the type document (i.e., CTA, MTOE, TDA, or JTA) which authorizes the item(s) to you.

Section II. ADDITIONAL AUTHORIZATION LIST FOR TENT, ARCTIC, 10-MAN

NSN 8340-00-262-3685

National Stock Number	Description, FSCM and Part Number	Usable On Code	U/M	Qty Auth
8340-00-262-5767	Repair Kit, Tentage (81349) MIL-C-3372	N/A	EA	1

Additional Authorization List for Tent, Assembly, Circus Type

NSN 8340-00-262-2877

National Stock Number	Description, FSCM and Part Number	Usable On Code	U/M	Qty Auth
5120-00-926-7116	Mallet, Wood (81349) LLL-M-71	N/A	EA	2
8340-00-262-5767	Repair Kit, Tentage (81349) MIL-C-3372	N/A	EA	1

Additional Authorization List for Tent, Command Post

NSN 8340-00-262-1370

National Stock Number	Description, FSCM and Part Number	Usable On Code	U/M	Qty Auth
5120-00-926-7116	Mallet, Wood (81349) LLL-M-71	N/A	EA	1
8340-00-262-5767	Repair Kit, Tentage (81349) MIL-C-3372	N/A	EA	1

Additional Authorization List for Tent, Hexagonal, Lightweight

NSN 8340-00-262-1372

National Stock Number	Description, FSCM and Part Number	Usable On Code	U/M	Qty Auth
8340-00-262-5767	Repair Kit, Tentage (81349) MIL-C-3372	N/A	EA	1

By Order of the Secretary of the Army:

Official:

CREIGHTON W. ABRAMS
General, United States Army
Chief of Staff

VERN L. BOWERS
Major General, United States Army
The Adjutant General

Distribution:

To be distributed in accordance with DA Form 12-25A, Operator Maintenance requirements for Tents: General Purpose and Lightweight.

RECOMMENDED CHANGES TO EQUIPMENT TECHNICAL PUBLICATIONS



THEN... JOT DOWN THE DOPE ABOUT IT ON THIS FORM. CAREFULLY TEAR IT OUT. FOLD IT AND DROP IT IN THE MAIL!

SOMETHING WRONG WITH THIS PUBLICATION?

FROM (PRINT YOUR UNIT'S COMPLETE ADDRESS)
 CDR, 1st Br, 65th ADA
 ATTN: SP4 J. Brown
 Key West, FL 33040

DATE SENT
 10 Jun 79

PUBLICATION NUMBER
 TM 9-1430-550-34-1

PUBLICATION DATE
 7 Sep 72 .

PUBLICATION TITLE Unit of Radar Set
 AN/MPQ-50 Tested at the HFC

BE EXACT PIN-POINT WHERE IT IS

PAGE NO	PARA-GRAPH	FIGURE NO	TABLE NO
---------	------------	-----------	----------

9-19

9-5

21-2

step
1C

21-2

SAMPLE

IN THIS SPACE TELL WHAT IS WRONG AND WHAT SHOULD BE DONE ABOUT IT:

"B" Ready Relay K11 is shown with two #9 contacts. That contact which is wired to pin 8 of relay K16 should be changed to contact #10.

Reads Multimeter B indicates 600 K ohms to 9000 K ohms.

Change to read Multimeter B indicates 600 K ohms minimum.

Reason Circuit being checked could measure infinity. Multimeter can read above 9000 K ohms and still be correct.

PRINTED NAME GRADE OR TITLE AND TELEPHONE NUMBER

SP4 J.T. Brown, Jr.

SIGN HERE

SP4 James Brown, Jr.

DA FORM 2028-2
 2 JUL 79

REPLACES DA FORM 2028 2 1 APR 78 WHICH WILL BE USED UNTIL EXHAUSTED
 AMMCM Overprint 1 Mar 91

P S --IF YOUR OUTFIT WANTS TO KNOW ABOUT YOUR RECOMMENDATION MAKE A CARBON COPY OF THIS AND GIVE IT TO YOUR HEADQUARTERS

TEAR ALONG PRIORITIZED LINE

RECOMMENDED CHANGES TO EQUIPMENT TECHNICAL PUBLICATIONS



THEN JOT DOWN THE DOPE ABOUT IT ON THIS FORM. CAREFULLY TEAR IT OUT. FOLD IT AND DROP IT IN THE MAIL!

SOMETHING WRONG WITH THIS PUBLICATION?

FROM (PRINT YOUR UNIT'S COMPLETE ADDRESS)

DATE SENT

PUBLICATION NUMBER

TM 10-8340-222-10

PUBLICATION DATE

21 NOV 72

PUBLICATION TITLE

TENT, GENERAL AND SPECIAL USE,
POLE SUPPORTED: ARTIC, 10-MAN

BE EXACT PIN-POINT WHERE IT IS

PAGE NO	PARA-GRAPH	FIGURE NO	TABLE NO

IN THIS SPACE TELL WHAT IS WRONG AND WHAT SHOULD BE DONE ABOUT IT:

PRINTED NAME GRADE OR TITLE AND TELEPHONE NUMBER

SIGN HERE

1 Nov 80

FILL IN YOUR
UNITS ADDRESS



FOLD BACK

DEPARTMENT OF THE ARMY

OFFICIAL BUSINESS

COMMANDER
U.S. ARMY AVIATION AND TROOP COMMAND
ATTN: AMSAT-I-MP
4300 GOODFELLOW BOULEVARD
ST. LOUIS, MO 63120-1798

TEAR ALONG PERFORATED LINE

THE METRIC SYSTEM AND EQUIVALENTS

WEIGHT MEASURE

1 Centimeter = 10 Millimeters = 0.01 Meters = 0.3937 Inches
 1 Meter = 100 Centimeters = 1000 Millimeters = 39.37 Inches
 1 Kilometer = 1000 Meters = 0.621 Miles

WEIGHTS

Gram = 0.001 Kilograms = 1000 Milligrams = 0.035 Ounces
 1 Kilogram = 1000 Grams = 2.2 lb.
 1 Metric Ton = 1000 Kilograms = 1 Megagram = 1.1 Short Tons

LIQUID MEASURE

1 Milliliter = 0.001 Liters = 0.0338 Fluid Ounces
 1 Liter = 1000 Milliliters = 33.82 Fluid Ounces

SQUARE MEASURE

1 Sq. Centimeter = 100 Sq. Millimeters = 0.155 Sq. Inches
 1 Sq. Meter = 10,000 Sq. Centimeters = 10.76 Sq. Feet
 1 Sq. Kilometer = 1,000,000 Sq. Meters = 0.386 Sq. Miles

CUBIC MEASURE

1 Cu. Centimeter = 1000 Cu. Millimeters = 0.06 Cu. Inches
 1 Cu. Meter = 1,000,000 Cu. Centimeters = 35.31 Cu. Feet

TEMPERATURE

$5/9(^{\circ}\text{F} - 32) = ^{\circ}\text{C}$
 212° Fahrenheit is equivalent to 100° Celsius
 90° Fahrenheit is equivalent to 32.2° Celsius
 32° Fahrenheit is equivalent to 0° Celsius
 $9/5^{\circ}\text{C} + 32 = ^{\circ}\text{F}$

APPROXIMATE CONVERSION FACTORS

TO CHANGE	TO	MULTIPLY BY
Inches	Centimeters	2.540
Feet	Meters	0.305
Yards	Meters	0.914
Miles	Kilometers	1.609
Square Inches	Square Centimeters	6.451
Square Feet	Square Meters	0.093
Square Yards	Square Meters	0.836
Square Miles	Square Kilometers	2.590
Acres	Square Hectometers	0.405
Cubic Feet	Cubic Meters	0.028
Cubic Yards	Cubic Meters	0.765
Fluid Ounces	Milliliters	29.573
its	Liters	0.473
arts	Liters	0.946
allons	Liters	3.785
Ounces	Grams	28.349
Pounds	Kilograms	0.454
Short Tons	Metric Tons	0.907
Pound-Feet	Newton-Meters	1.356
Pounds per Square Inch	Kilopascals	6.895
Miles per Gallon	Kilometers per Liter	0.425
Miles per Hour	Kilometers per Hour	1.609

TO CHANGE	TO	MULTIPLY BY
Centimeters	Inches	0.394
Meters	Feet	3.280
Meters	Yards	1.094
Kilometers	Miles	0.621
Square Centimeters	Square Inches	0.155
Square Meters	Square Feet	10.764
Square Meters	Square Yards	1.196
Square Kilometers	Square Miles	0.386
Square Hectometers	Acres	2.471
Cubic Meters	Cubic Feet	35.315
Cubic Meters	Cubic Yards	1.308
Milliliters	Fluid Ounces	0.034
Liters	Pints	2.113
Liters	Quarts	1.057
ers	Gallons	0.264
ms	Ounces	0.035
ograms	Pounds	2.205
Metric Tons	Short Tons	1.102
Newton-Meters	Pounds-Feet	0.738
Kilopascals	Pounds per Square Inch	0.145
ometers per Liter	Miles per Gallon	2.354
ometers per Hour	Miles per Hour	0.621

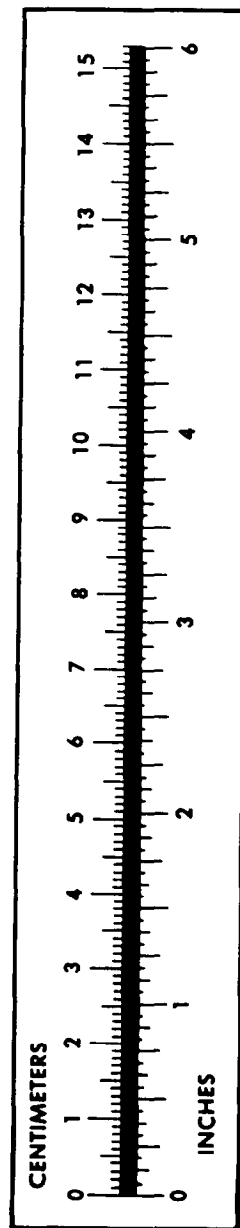

PIN: 028537-003

This fine document...

Was brought to you by me:



[Liberated Manuals -- free army and government manuals](#)

Why do I do it? I am tired of sleazy CD-ROM sellers, who take publicly available information, slap “watermarks” and other junk on it, and sell it. Those masters of search engine manipulation make sure that their sites that sell free information, come up first in search engines. They did not create it... They did not even scan it... Why should they get your money? Why are not letting you give those free manuals to your friends?

I am setting this document FREE. This document was made by the US Government and is NOT protected by Copyright. Feel free to share, republish, sell and so on.

I am not asking you for donations, fees or handouts. If you can, please provide a link to liberatedmanuals.com, so that free manuals come up first in search engines:

<A HREF=<http://www.liberatedmanuals.com/>>Free Military and Government Manuals

– Sincerely
Igor Chudov
<http://igor.chudov.com/>